

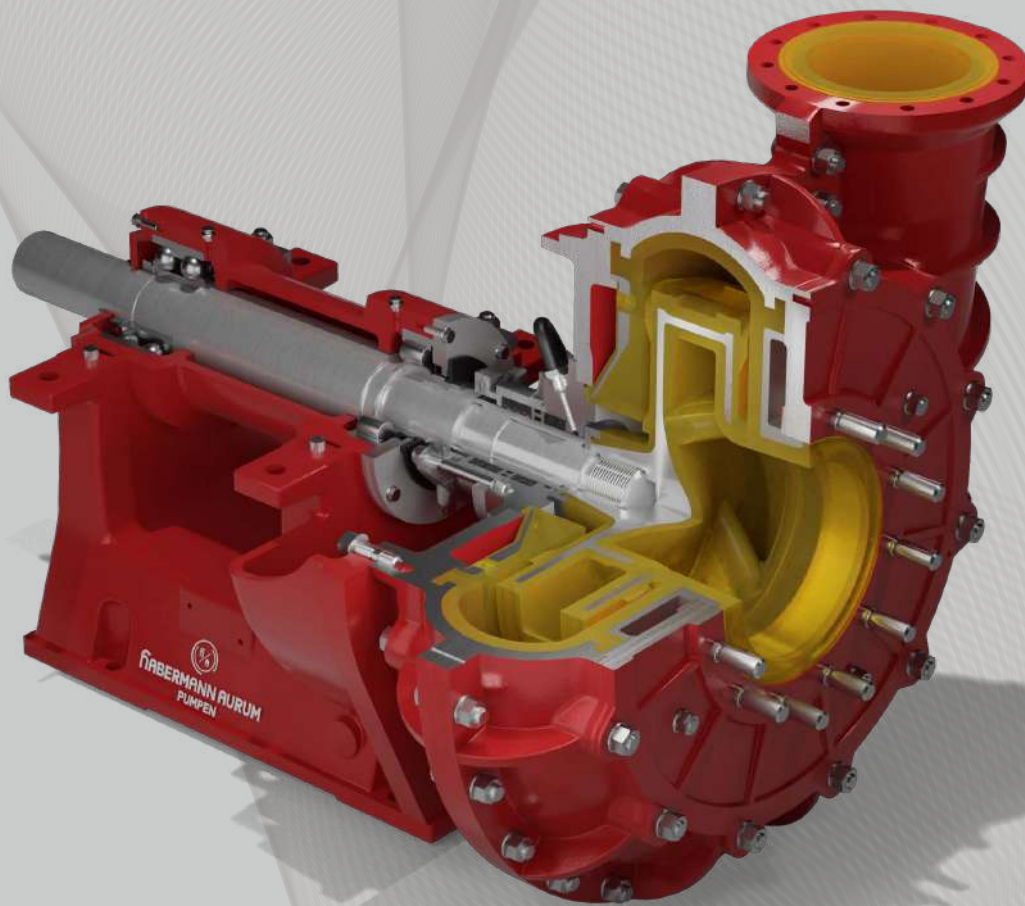

HABERMANN AURUM PUMPEN



**SLURRY PUMPS
FOR ABRASIVE AND CORROSIVE MEDIA**

MADE IN GERMANY



HABERMANN AURUM PUMPEN has been offering reliable solutions and extensive know-how in slurry transportation since 1927.

1927

Habermann Aurum Pumpen is one of the leading manufacturers of centrifugal pumps, ideal for processing slurries. With almost 100 years of experience and more than 30,000 pumps installed worldwide, serving various applications, we have built a strong market position across the globe. Our fundamental goal is to create the

most durable and sustainable industrial pumps by combining our multi-decade experience with the state-of-the-art technologies. Our pumps are integrated into a wide variety of industries, such as: mining and mineral processing, energy industry, metallurgy, chemical and pigment industries, tunnelling and special civil engineering. We are continuously improving our pumping systems to ensure their exceptional quality and optimal performance capabilities. Based on the technical skills of our work force, we customize and manufacture pumps you can rely on, most of which have been in trouble-free operation for more than 60 years, which speaks for their longevity, safety and efficiency.

We always ensure your industrial needs are covered with our proven operational designs combined with the most reliable and robust materials to make a functional unit. Our broad product line of pumps, valves and fittings complies with the most diverse and challenging pumping requirements. Thanks to our in-house engineering we can find solutions to any system demand, regardless of technical complexity or application conditions.

We have built an excellent quality profile, which allowed us to establish Habermann Aurum as a high-valued and reliable partner for industrial pumping systems. We proudly design, produce and install our pumps all over the world. Through

our network of partners and branch offices, our market presence extends across continents from Europe to America, Asia and Africa. We are well prepared to meet current and future market demands and to support our customers in the best possible way.

Tradition meets modern technologies.



www.habermann-aurum-pumpen.de



**COMPLETE PUMP SOLUTIONS
FOR ANY SLURRY TYPE**

CONTENTS

ABOUT US	2
COMMON APPLICATIONS	6
HPK SERIES	8
POLYURETHANE AND RUBBER LINING	14
CERAMCARBIDE COATING	16
NPK, NP SERIES	18
NPW SERIES	22
RPL SERIES	26
KB, KBK, KBH, KBKM SERIES	28
CHALLENGER & HERACLES	32
VERTICAL PUMPS	36
SPECIAL SUMP DESIGN N	42
SHAFT SEALS	44
CASTING MATERIALS	50
DRIVES AND INSTALLATION TYPES	52
PUMP CONFIGURATIONS	53
PUMP SERVICE	54



Chemical	HPK	NPK	NPW	KB
Separation	•	•	•	
Abrasive chemicals	•	•		
Precipitates, sodium	•	•	•	
Foaming liquids	•	•		
SO4, chloride	•	•		
Fertilizers, PO4	•	•		
Solvents, pigments	•	•		
Recycling	•	•	•	•
Crude oil residues			•	

Quarrying & Aggregates	HPK	NPK	NPW	KB
Sand & gravel extraction	•	•	•	•
Wet sand treatment	•	•	•	•
Limestone slurry	•	•	•	
Slate, marble, granite	•	•	•	•
Kaolin, clay	•	•	•	
Cyclone separation	•	•		
Dredging (harbors, rivers)		•		•

Mining	HPK	NPK	NPW	KB
Coal, ore, phosphates, potash, bauxite	•	•	•	•
Heavy mining slurry	•	•	•	•
Ore slurry	•	•	•	•
Ferric oxide production	•	•	•	•
Fe, Zn, Cu, Ti, salt, Al, etc.	•	•	•	•
Mill scale and separation	•	•	•	•
Frothy slurry	•	•		
Waste recycling	•	•	•	
Thickener underflow	•	•		
Chamber filter press	•	•		



Metallurgy & Energy Industry	HPK	NPK	NPW	KB
Coal & coke processing	•	•	•	•
Hot rolling mills	•	•	•	•
Sinter & scale	•	•	•	
Blast furnaces	•	•	•	•
Bottom ash	•	•	•	•
Flue gas desulphurization	•	•		
Condensates			•	

Tunneling, Construction & Civil Engineering	HPK	NPK	NPW	KB
Tunnel construction			•	•
Vertical trenching (wet and dry wells)			•	•
Ready-mix concrete		•	•	
Aerated concrete	•			
Bentonite and cement mixing	•	•	•	
Deep mining - diaphragm wall cutter				•

Agriculture	HPK	NPK	NPW	KB
Sugar industry, beet pulp		•	•	•
Biogas, fertilizers		•		
Livestock waste		•	•	•
Washing installations	•	•	•	•
Organic slurry	•	•	•	
Sewage treatment systems	•	•	•	



HPK

HPK SERIES

PUMPS WITH ELASTIC LINING OF ALL INNER PARTS EXPOSED TO THE SLURRY

The design is intended to withstand **the highest slurry temperatures** of up to 130 degrees Celsius.

130°C

Centrifugal pumps of HPK series are widely used in extreme wear applications and have a proven track record of high resistance to aggressive chemicals, in particular acids and chlorides. The key attribute of these pumps is their inner lining of all wet parts with elastic materials, such as polyurethane and rubber, which slow down the abrasion process and serve as a

protective layer. These durable and long-lasting materials enhance pump's internal resistance to stress and corrosion by chloride-bearing fluids and significantly decrease its wear issues. Another lining option for HPK series is our special CeramCarbide coating, which provides a quantum improvement over a single metallic casing and offers a greater resistance to high concentration of acids. This particular material can sustain solid particles up to a maximum size of 5-10 mm. For convenience, the pump casing design of HPK Series was optimized to allow easy replacement of all wear parts and simplified maintenance.

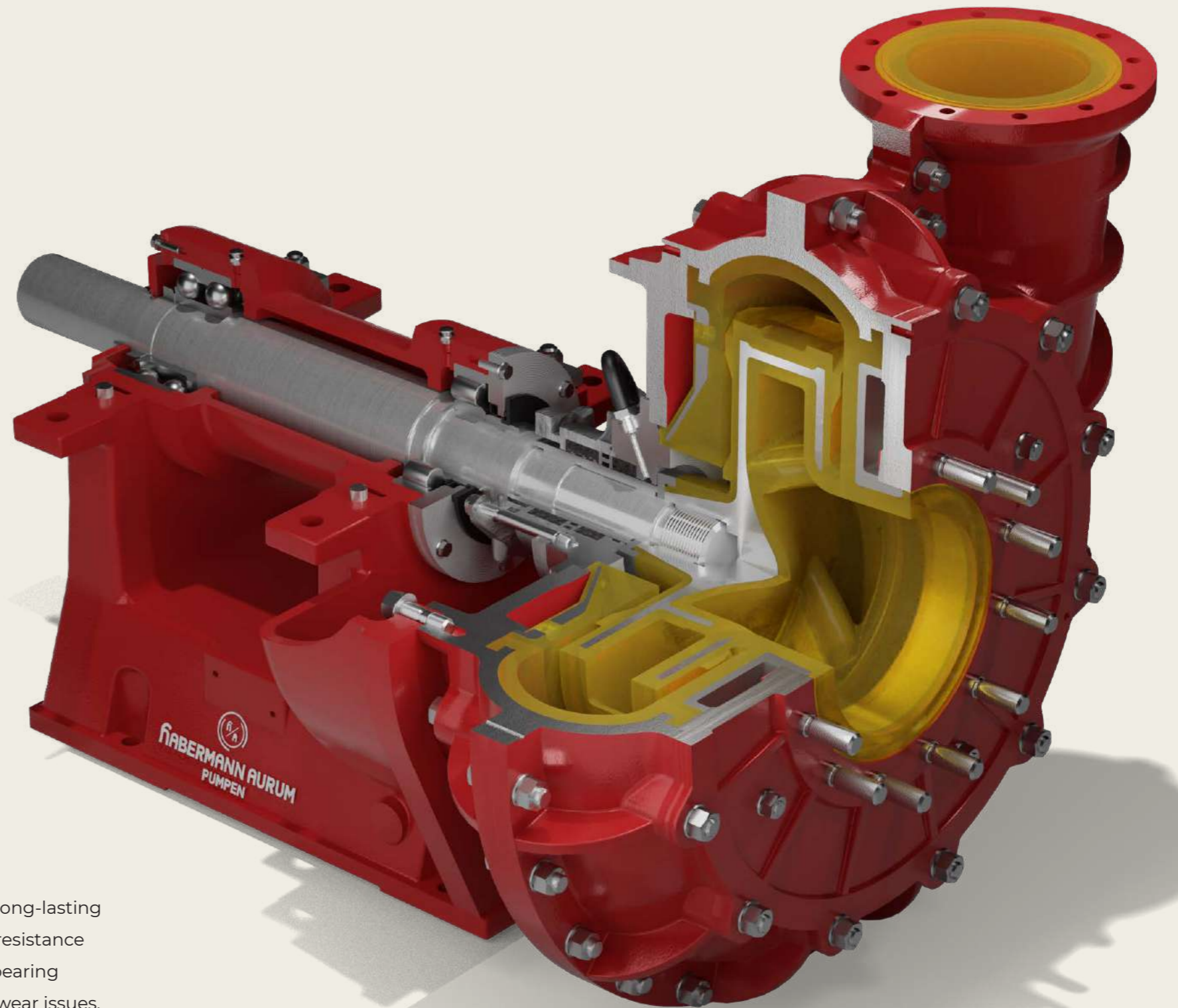

Find more information on this pump type visiting our website.

HPK SERIES

PUMPS WITH ELASTIC LINING OR CERAMCARBIDE COATING

All parts of the unit interacting with the pump media are protected with a hard-wearing lining to eliminate the damage under demanding applications. Our wide range of high-quality lining materials ensures exceptional resistance against wear for abrasive and corrosive media. Pumps with elastic lining consist of ductile iron outer housing and an inner protection layer. Our CeramCarbide coating is a non-metallic lining which covers walls of the casing, as well as some other pump parts. The appropriate lining solution is determined according to working fluid properties, its temperature and the average particle size.



COMMON APPLICATIONS

CHEMICAL
Waste recycling, SO₄, chloride, separation, precipitates, sodium, foaming liquids, pigments, fertilizers, PO₄, aggressive chemicals

AGGREGATES
Sand and gravel extraction, dewatering, wet treatment, mineral processing

METALLURGY & ENERGY INDUSTRY
Ash removal, condensates, coal and coke processing, flue gas desulphurization

SUGAR PRODUCTION AND AGRICULTURAL WASTE
Washing installations, organic slurry, biogas, fertilizers, sewage treatment systems

MINING
Chamber filter press, waste recycling, slurry and sump pumps, thickener underflow, separation, ferric oxide production, ore slurry, Fe, Zn, Cu, Ti, salt, Al, etc., frothy slurry, ceramics, glass waste

TUNNELLING, CONSTRUCTION AND SPECIAL CIVIL ENGINEERING
Kaolin, clay, slate, marble, granite, sand & gravel, aerated concrete, limestone slurry, bentonite and cement mixing, cyclone separation

STEEL INDUSTRY
Sinter and scale, blast furnaces, hot rolling mills

PERFORMANCE CHARACTERISTICS OF HPK

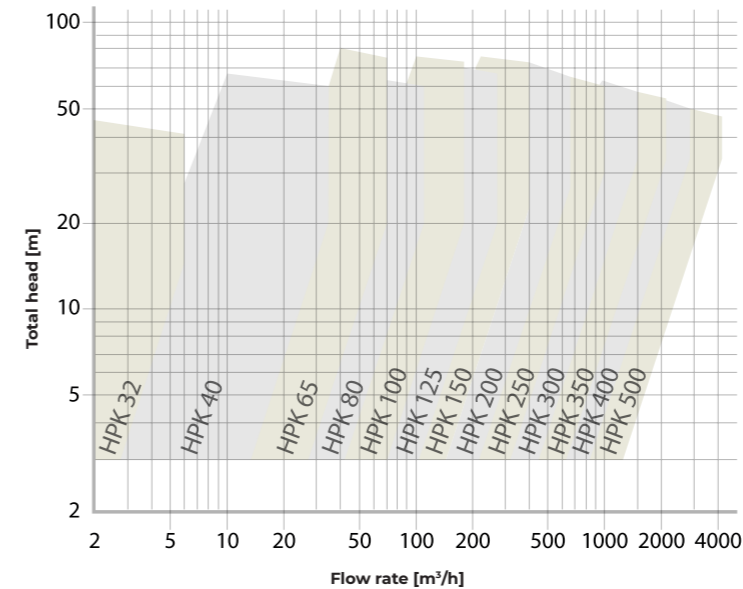

Performance characteristics of HPK

Flow rate, up to	4600 [m ³ /h]
Maximum head	70 [m.l.c]
Pump speed, depending on the size, up to	2950 [min ⁻¹]
Pump sizes	DN 32 to DN 500
Maximum operating pressure	10 to 40* [bar]
Temperature of the slurry, up to	130 [°C]
Static head	8 [mW.C.]
Discharge nozzle arrangement	rotatable
Highly corrosion resistant at pH levels	0 to 14 depending on material

*Special design

POLYURETHANE APFlex

All wear parts that come into direct contact with process fluid have special elastic lining, which is selected based on individual application requirements and only after careful evaluation of the abrasive, thermal and chemical properties of the fluid. Read more on page 14.

CeramCarbide COATING

This special coating is mainly used for critical applications, comparable with corrosive and abrasive media with the maximum particle size of 10mm.

LINING SOLUTIONS

RUBBER

All wet parts of the pump are protected with special rubber lining. This particular solution is ideally suited for pumping fluids with high temperatures.

METALLIC VARIANT

Fully metallic pump design, made from high-alloy cast material, is also available for special applications.

MATERIAL VARIANTS DEPENDING ON SLURRY TYPE

Slurry Characteristics	Metallic	Rubber	Polyurethane APFlex	CeramCarbide
Fine-grained, rounded shape		X	X	X
Fine-gained, sharp-edged < 5 mm	X	X	X	X
Abrasive, sharp-edged > 5 mm	X			
Coarse-grained > 5 mm	X			
Chemically aggressive	X	X	X	X



REPLACEABLE PARTS

Outer casing	Ref.	Bearing unit	Ref.	Wear parts	Ref.
Front casing cover	30	Bearing bracket	219	Closed impeller	60
Back casing cover	80	Bearing housing	217	Suction side plate	40
Front half casing	130	Shaft	218	Discharge side plate	70
Back half casing	150			Inner lining	50

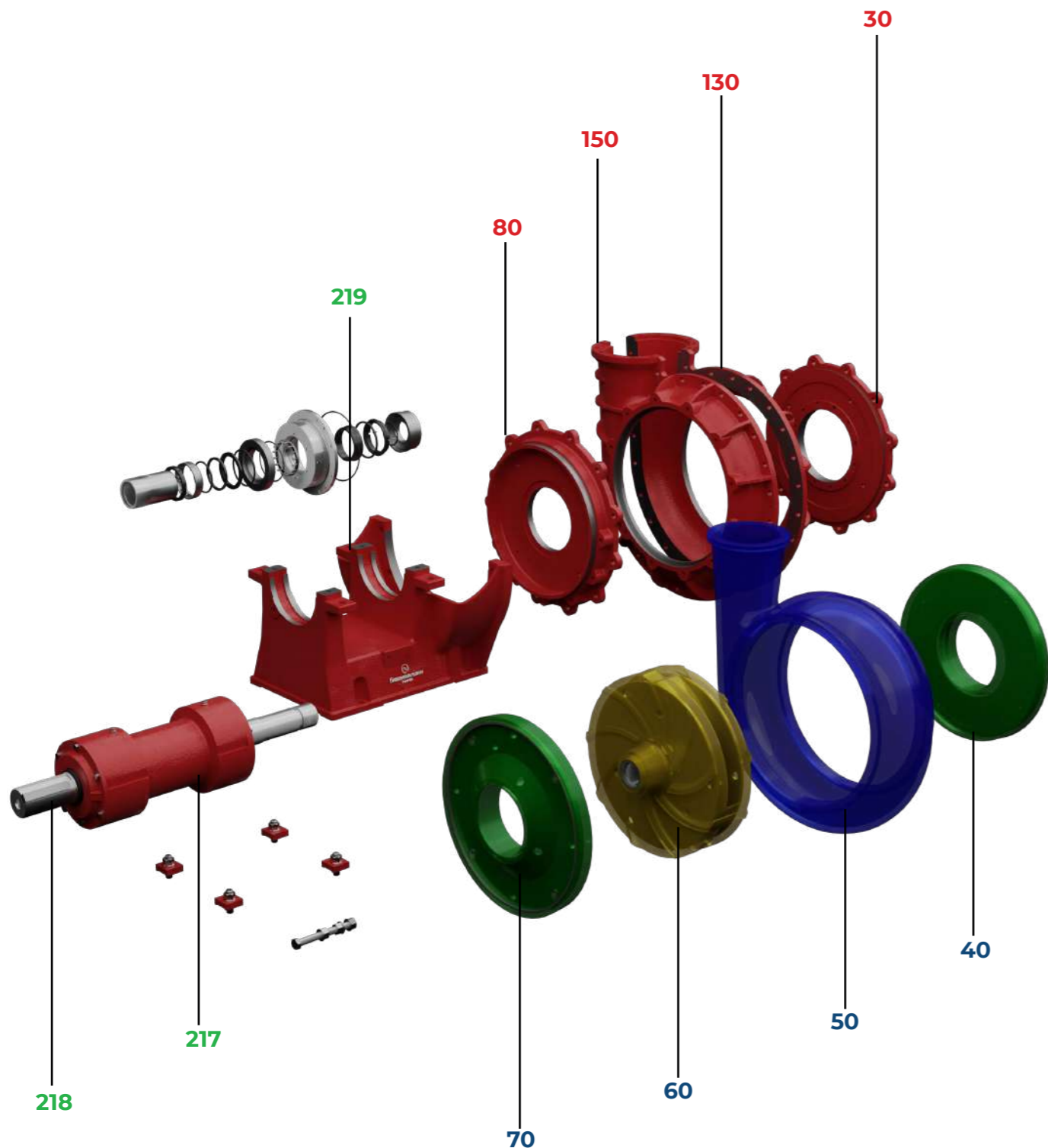

The HPK Series are single-stage centrifugal pumps equipped with protective lining of all wear parts and an adjustable clearance on the suction side.

Wear Plates on Suction and Discharge Sides	Impeller	Inner Lining made of Elastic Materials
Both wear plates have metallic body, which is lined with either polyurethane APFlex or rubber. The elastic material is vulcanized to ensure an optimal bond. The wear plates are screwed tight to the pump casing cover to ensure the highest rigidity.	The impeller also has a metallic body lined with our elastic materials. Closed and semi-open impellers are typically used for HPK pumps, three- or four-blade configurations are also available. The cover plates of the impeller are equipped with relief vanes, which allow to relieve the pressure on the shaft seal and reduce the backflow of the slurry.	The outer pump casing is protected against wear and corrosion with our Polyurethane APFlex or rubber lining. Depending on the operating pressure, the outer casing is configured either in ductile cast iron or stainless steel, suitable for higher pressures of up to PN25. For more details on protective lining, please see pages 14-17.

POLYURETHANE AND RUBBER

INNOVATIVE POLYURETHANE APFlex

Based on polyurethane's excellent elastic properties, it is ideal for the inner lining of pump parts and is highly effective in achieving the so-called "trampoline effect", which presents a great advantage in pump wear behavior with abrasive and corrosive media. APFlex easily adapts to the fine-grained slurries with particle size up to 5 mm and in some cases up to 10 mm, as well as high temperatures. Due to its elasticity, high tear and chemical resistance, this material is far superior to any wear-resistant castings, which translates to lower operating expenses and extended service life.

AP 10-01

Is abrasion and corrosion resistant, suitable for acids or alkalis and offers good oil resistance

AP 60-01

Is suitable for sand and gravel, particularly abrasion-resistant and exceptionally durable against reconditioned oils

AP 50-01

Is a further refined AP 10-01, which enables higher temperature resistance

Rubber APG 2201, APG 2210

Withstands the highest slurry temperatures and provides abrasion and corrosion resistance



POLYURETHANE AND RUBBER CHARACTERISTICS

Type	APFlex 10-01 (yellow)	APFlex 60-01 (green)	APFlex 50-01 (blue)	APG 2201	APG 2210
Shore hardness	A 88-90	A 75-80	A 88-90	65	55
Temperature	-30 to +75 °C	-30 to +75 °C	-30 to +95 °C	100-105 °C	max. 130 °C
pH	0-14	5-9	0-14	0-14	0-14
Special features	Suitable for acids and alkalis	Extra abrasion resistant	Suitable for acids and alkalis	Suitable for acids and alkalis	Suitable for acids and alkalis

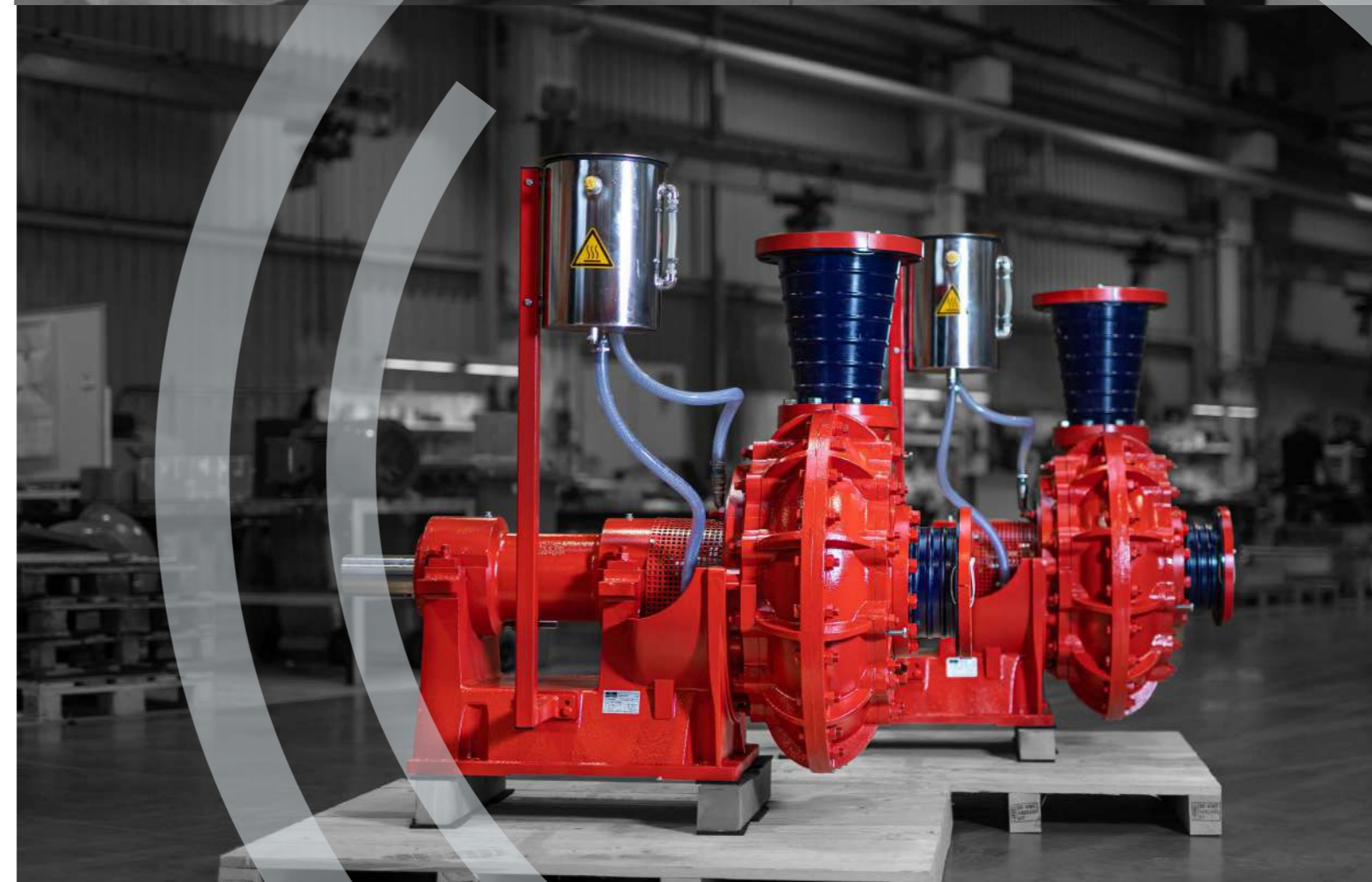

CERAMCARBIDE COATING FOR HPK PUMPS

HIGHLY WEAR-RESISTANT SLURRY PUMP HPK WITH POLYMER CAST LINING

Our further improvement of pump performance is the use of CeramCarbide, a non-metallic composite material consisting of 80% silicon carbide and 20% vinyl ester resin as a binder. The pump wet parts are coated with CeramCarbide which is particularly used for application with hypochlorite and highly concentrated acids and alkalis. CeramCarbide is a good choice for applications with sliding wear and is very resistant to high temperatures.



The wear parts coated with CeramCarbide are 100% identical to pump wear parts protected with polyurethane lining of the HPK series.

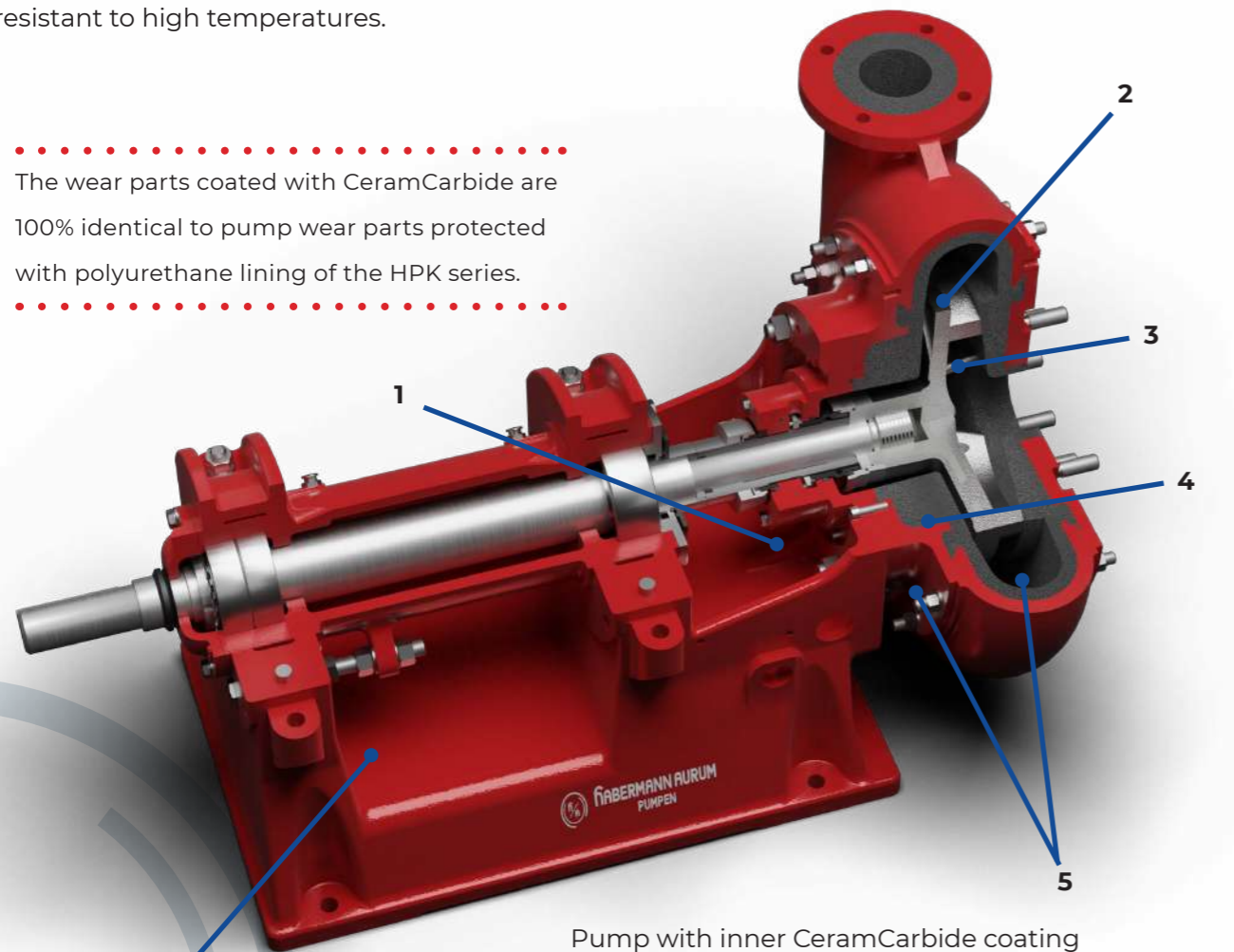

Pump with inner CeramCarbide coating

MAIN FEATURES

1. Double mechanical seal HGD-2 with thermosiphon cooling system has proven effective in processing high concentration of solids.
2. One-piece, cast iron outer casing for optimum performance under high operating pressures.
3. All wet parts of the pump are coated with CeramCarbide, which forms another protective layer.

4. Open, thick blade impeller with CeramCarbide coating. Under certain conditions, a metallic design of the impeller either in high chrome tempered casting or duplex stainless steel can also be accommodated.

5. Thick-walled, easily to replace wear plates on suction and discharge sides.

6. Axial displacement in the bearing unit enables an easy clearance adjustment between the impeller and wear plate on the suction side.

CERAMCARBIDE MATERIAL

Silicon carbide is a non-oxide ceramic with exceptional properties. It is the lightest, but also the hardest ceramic material, its hardness (HV10>22GPa) is similar to that of diamonds. Silicon carbide exhibits excellent resistance to acids and alkalis and can withstand wear and corrosion at high temperatures.

Vinyl ester resin, also referred to as VE-resin, is a synthetic compound material, which after hardening results in a thermosetting material of great strength and chemical resistance. VE-resins are often used in the production of fiberglass, specifically for chemical equipment (containers, pipes, cooling towers), in addition to technical, chemical and thermal applications.



OUTTER CASING

One-piece metallic outer casing with inner coating as protection layer

SHAFT SEAL

Proven Habermann Aurum double mechanical seal HGD-2/ HN 401

IMPELLER

Open, three-blade impeller includes a metallic body and protective coating

WEAR PLATES

On suction and discharge sides, easily serviced and replaced, with pump casing cover made of ductile iron

ADVANTAGES

- Double-protection casing design ensures safe operation even under high operating pressures
- Advanced structural stability in high impact and aggressive chemical applications
- Permissible pressure of up to PN 10 (higher operating pressures are allowed, depending on the outer casing material)
- Durable one-piece casing eliminates tear and wear issues

NPK

NPK SERIES

HEAVY DUTY PUMPS MADE OF HIGHLY WEAR-RESISTANT CAST MATERIAL

The durable protective materials are made of highly wear and corrosion-resistant casting with hardness up to 650 HB according to Brinell.

650 HB

The NPK series are robust, single-stage centrifugal pumps with an easy replacement of wear parts and an adjustable clearance on the suction side. The casing and the wear plates are connected with two casing covers by means of tie rods. This unique anchor assembly provides optimum stability, high hardness level and a

longer service life of the unit. Due to the use of advanced materials, this pump type can be used for corrosive and abrasive media with a particle size of up to 150 mm. The Impeller, wear plates and casing have an ample wall thickness and optimized sizes to achieve the highest attainable efficiency. These rugged, hard-working pumps tackle the toughest applications and have the lowest operational expenses.

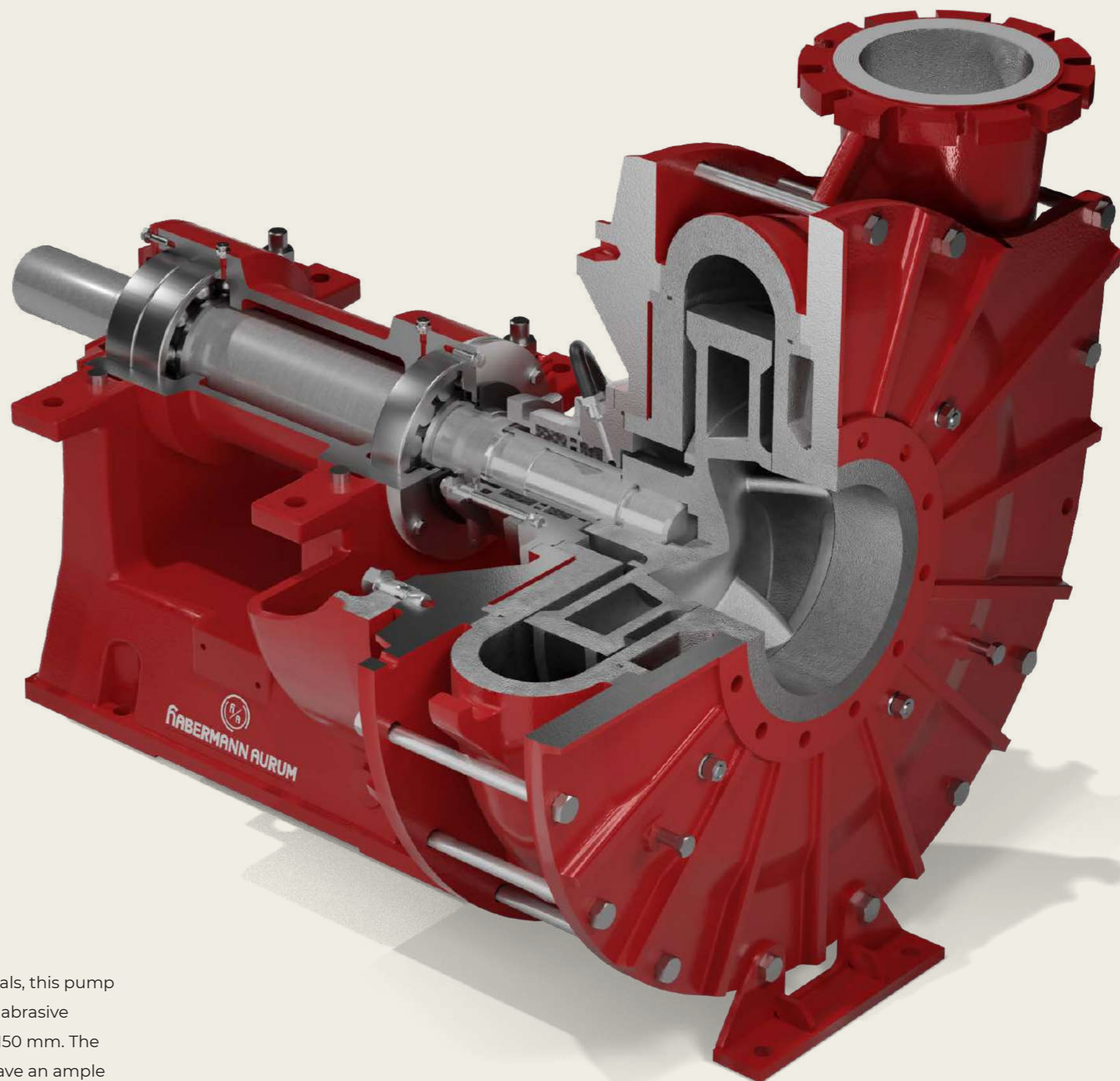

Find more information about this type on our website

NPK/ NP SERIES

SLURRY PUMPS MADE OF HIGHLY WEAR-RESISTANT CAST MATERIALS

NPK slurry pumps are mainly used in medium to high wear applications. The practical design of the casing walls, wear plates and impeller, which are designed to precise thickness and size, is guaranteed to withstand extreme operating conditions with high head rates and coarse-grained solids. Our strategical anchor structure of the pump with tie rods over the casing covers is intended to optimize unit structural stability, increase the mechanical strength and extend its life span. The **NP design** was developed for higher operating pressures up to 25 bar. The NP design has an inner protective finish and a second external casing to ensure an ultimate impact resistance under high pressures.



COMMON APPLICATIONS

STEEL INDUSTRY
Sinter and scale precipitates, blast furnaces, hot rolling mills

AGGREGATES
Sand and gravel extraction, dewatering, wet treatment, mineral processing

ENERGY INDUSTRY
Condensates, coal and coke processing, flue gas desulphurization

TUNNELLING, CONSTRUCTION AND SPECIAL CIVIL ENGINEERING
Kaolin, clay, slate, marble, granite, sand & gravel, micro tunnelling, limestone slurry, vertical trenching (wet and dry wells), bentonite and cement mixing, dredging (harbors, rivers), ready-mix concrete, cyclone separation

SUGAR PRODUCTION AND AGRICULTURAL WASTE
Beet pulp, washing installations, livestock waste, biogas, fertilizers, wastewater treatment systems

MINING
Heavy mining slurry, chamber filter press, waste recycling, slurry and sump pumps, thickener underflow, mill scale and separation, ore slurry, iron oxide production, fibrous slurry, coal, ore, phosphates, potash, bauxite, frothy slurry, ceramics, glass waste, Fe, Zn, Cu, Ti, salt, Al, etc.

CHEMICAL
Waste recycling, SO₄, chloride, separation, precipitates, sodium, foaming mixtures, pigments, fertilizers, PO₄, aggressive chemicals

PERFORMANCE CHARACTERISTICS OF NPK

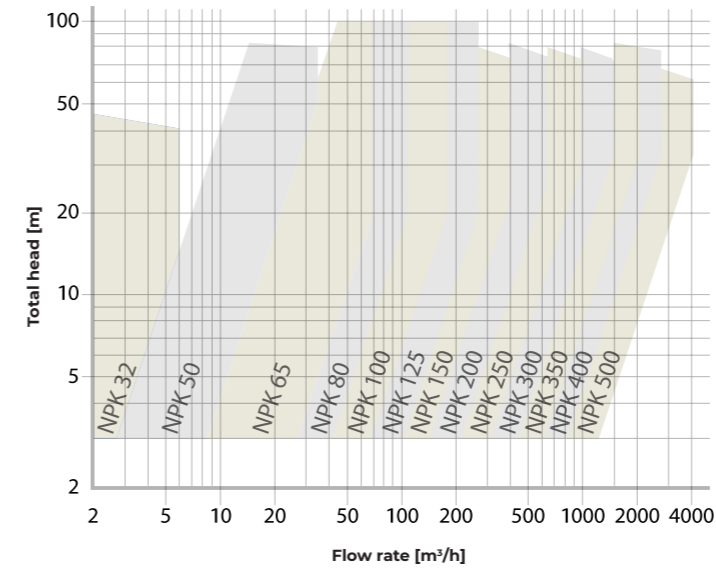

Performance characteristics of NPK	
Flow rate, up to	4600 [m ³ /h]
Maximum head	95 [m.l.C]
Pump speed, depending on the size, up to	2950 [min ⁻¹]
Pump sizes	DN 32 to DN 500
Maximum operating pressure	10, 16, 25 [bar]
Temperature of the slurry, up to	max. 90 [°C]
Static head	8 [mW.C.]
Discharge nozzle arrangement	rotatable
Highly corrosion resistant at pH levels	3 to 14 depending on material

The properties of the media determine the material required. To better accommodate various application requirements, we offer our high-alloy HBN cast materials, which have been perfected through our continuous research and development process. These materials are characterized by their outstanding wear and corrosion resistance, high hardness level and ability to endure the abrasive nature of solids.

- **440**
wear resistant cast material, Ni-Hard IV successor, hardness up to 600 HB
- **450**
highly wear resistant, tempered cast material, hardness up to 650 HB



- **480**
corrosion resistant, tempered cast material, hardness up to 620 HB

ADVANTAGES

- Ideal for conveying abrasive, solid and large particles
- Suitable for rough operating conditions
- Components exposed to the slurry are wear-resistant, corrosion resistant
- Service-friendly design



NPK 150/630 V2

NPW

NPW SERIES

IDEAL FOR INDUSTRIAL SLURRY

Our special tempered casting HBS is a result of our continuous research and improvement.

HBS

The HBS series are heavy-duty, single-stage metallic centrifugal pumps with easy replacement of wear parts and an adjustable clearance on the suction side. To further satisfy

various industrial requirements, the impeller, wear plate and casing are carefully and properly sized to achieve the longest possible service life and improve pump overall performance. Even under the toughest conditions, the NPW pumps have the lowest life-cycle costs.

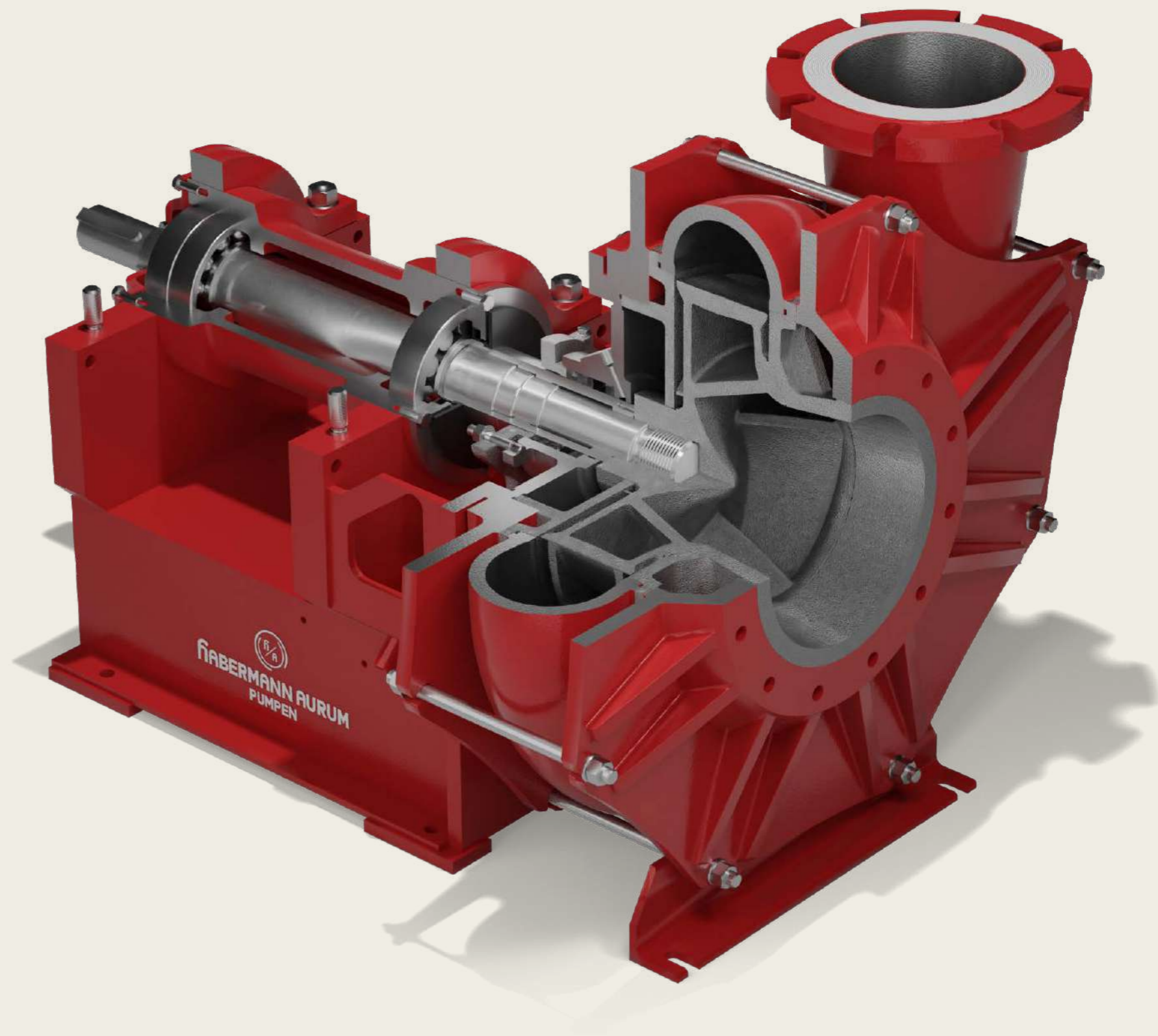

Find more information about this type on our website.

NPW SERIES

IDEAL TO PROCESS INDUSTRIAL SLURRIES

The NPW metallic centrifugal pumps are mainly used in light to medium wear applications. This series allow easy replacement of wear parts and feature an anchor assembly with tie rods over the casing covers to guarantee maximum operating efficiency.



COMMON APPLICATIONS

AGGREGATES

Sand and gravel extraction, dewatering, wet treatment, mineral processing

ENERGY INDUSTRY

Bottom ash, coal and coke processing

SUGAR PRODUCTION AND AGRICULTURAL WASTE

Organic slurry, biogas, fertilizers, wastewater treatment systems

MINING

Heavy mining slurry, slurry and sump pumps, separation, ore slurry, coal, ore, phosphates, potash, bauxite, ceramics, Fe, Zn, Cu, Ti, salt, Al etc.

TUNNELING, CONSTRUCTION & SPECIAL CIVIL ENGINEERING

Kaolin, clay, slate, marble, granite, sand and gravel, micro tunneling, limestone slurry, vertical trenching (dry and wet wells), bentonite and cement mixing, ready-mix concrete

STEEL INDUSTRY

Sinter and scale precipitates, blast furnaces

PERFORMANCE CHARACTERISTICS OF NPW

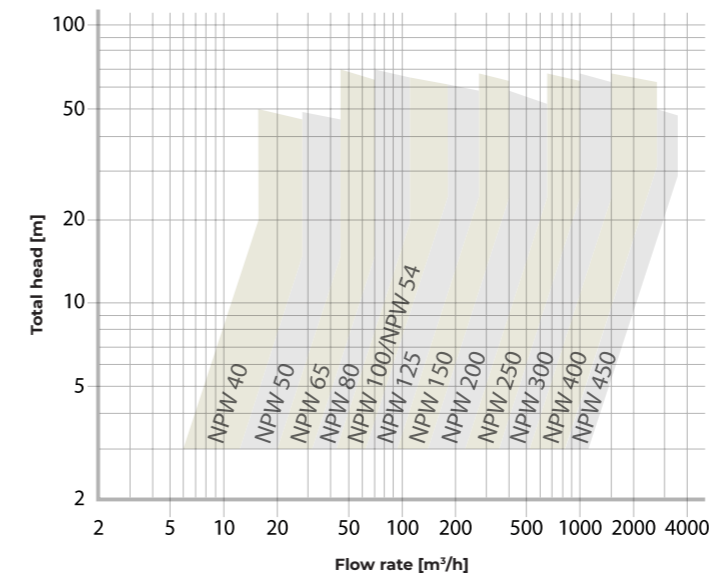

Performance characteristics of NPW

Flow rate, up to	4600 [m³/h]
Maximum head	70 [m.l.c]
Pump speed, depending on the size, up to	2950 [min ⁻¹]
Pump sizes	DN 40 to DN 450
Maximum operating pressure	6 [bar]
Temperature of the slurry, up to	90 [°C]
Static head	8 [mW.C.]
Discharge nozzle arrangement	gradually rotatable
Highly corrosion resistant at pH levels	3 to 14 depending on material

The NPW series are cost-effective pumps for handling various kinds of abrasive media in the following applications:

- Stone slurry processing
- Slurry feed pump in tunnelling
- Mixer pump for the ready-mix concrete production

ADVANTAGES

- optimized quality materials for low operating expenses
- cost-effective version of pumps for tough applications



NPW 50/250

SPECIAL DESIGN RPL

LIGHTWEIGHT CONSTRUCTION OF THE PUMP WITH PROTECTIVE FINISH FOR MEDIUM WEAR APPLICATIONS

Our resource efficient RPL pumps with protective metallic finish are designed for light to medium wear applications with low content of soft and solid particles, such as wastewater and coal pulp processing. RPL series are durable, cost-saving pumps that have been proven effective for many years.

This type is one of the first pumps developed by Habermann, which has been further improved and modified to best serve current industrial needs. RPL pumps have had considerable success in applications, such as dewatering, slurry processing and water treatment in tunneling. Based on individual requirements, you can choose either closed or semi-open impellers. Additionally, two-, three-, or four-blade impellers are also available. Trapezoidal thread accommodates impeller on the shaft. To relieve the pressure on the shaft seal, both casing covers of the impeller are equipped with relief blades on the back side. The pump casing, as well as the bearing casing, are provided with robust bearing bracket.

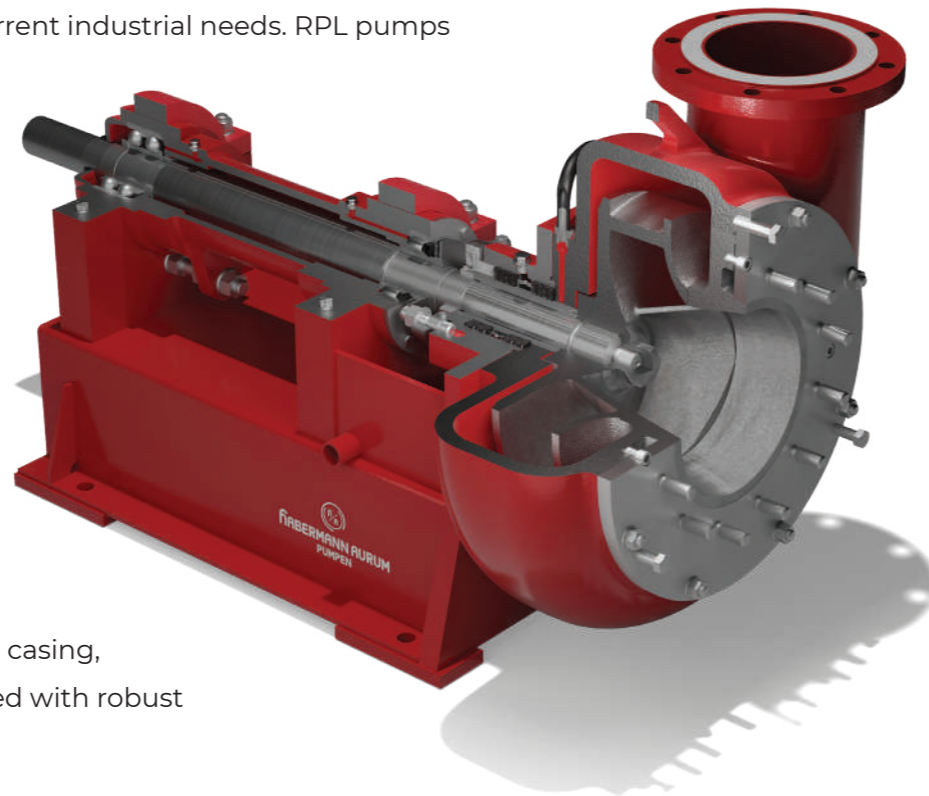

The hydraulic part of the pump, which is easy to install and disassemble, essentially consists of four components:

- Impeller
- Casing with protective finish
- Suction side wear plate
- Drive side wear plate

Performance characteristics of RPL

Flow rate, up to	3000 [m ³ /h]
Maximum head	125 [m.l.c]
Pump speed, depending on the size, up to	2950 [min ⁻¹]
Pump sizes	DN 32 to DN 400
Maximum operating pressure	10, 16 [bar]
Temperature of the slurry, up to	90 [°C]
Static head	8 [mW.C.]
Discharge nozzle arrangement	gradually rotatable
Highly corrosion resistant at pH levels	3 to 14 depending on material



KB

KB, KBK, KBH, KBKM, KBKT SERIES

DREDGING PUMPS FOR TUNNEL CONSTRUCTION
AND SPECIAL CIVIL ENGINEERING

Pumps with discharge connection up to DN 500
for various applications.

DN500

These compact, wear resistant and corrosion resistant pumps have been designed for particularly demanding conditions in tunnel construction, dredging and special civil engineering for pumping aggressive media. Our

KB, KBH, KBK, KBKM, KBKT series are intended to be used as feed or drainage pumps. Moreover, the compact construction of KB and KBH is well-suited for limited installation conditions, for instance in micro-tunneling and pipe jacking. Robust casing walls have ample thickness that allows the pump to withstand continuous pumping of small solid particles, as well as the abrasion impact caused by a high volume of coarse solids.

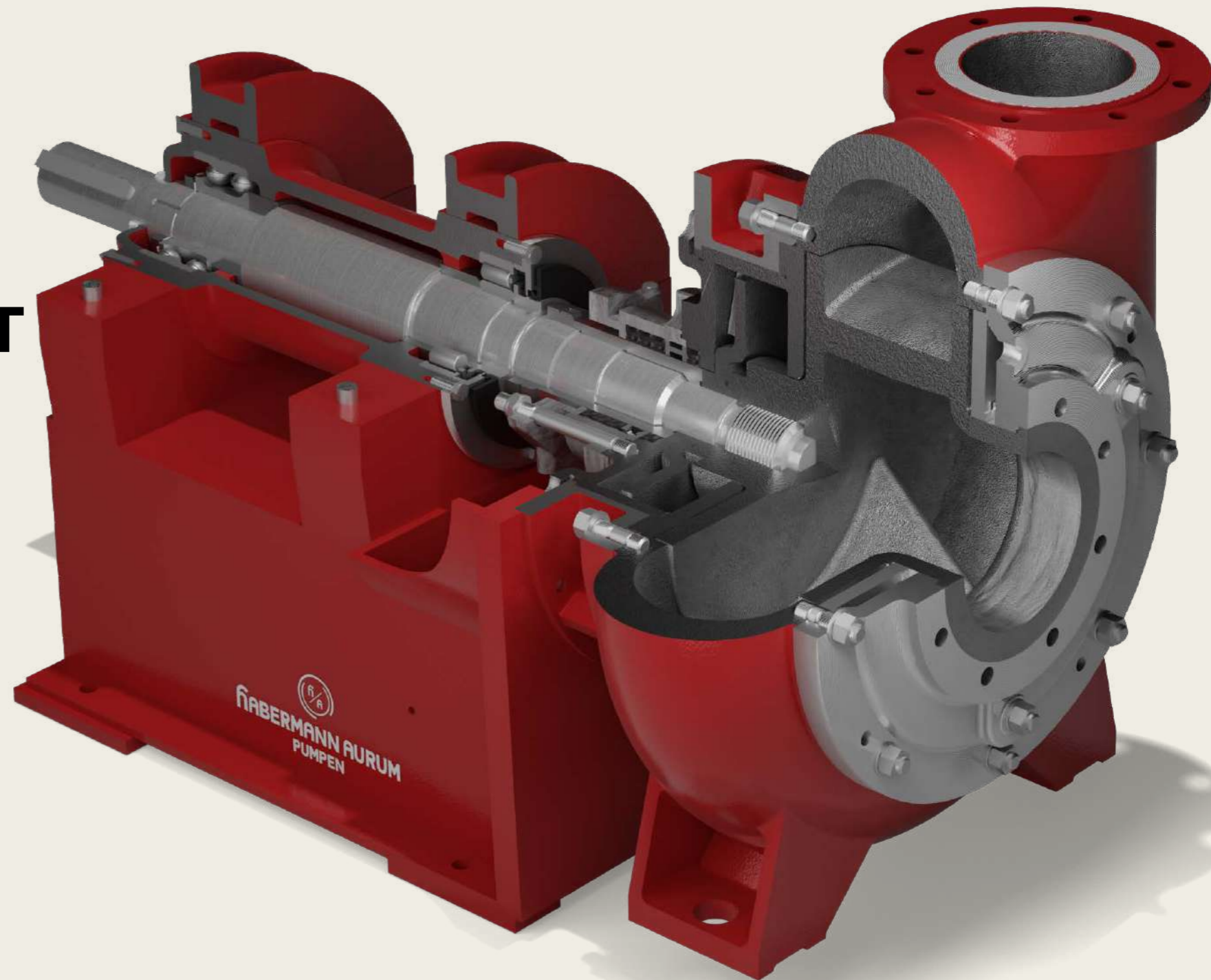

Find more information about this series on our website.

KB / KBK / KBH / KBKM / KBKT SERIES

HEAVY-DUTY PUMP SERIES

The metallic centrifugal slurry pumps are the best fitting designs for the toughest, high-wear applications. Our robust gravel and dredging pumps of KB series are designated for handling coarse material and gravel extraction. Numerous operators and manufacturers around the world rely on our high load bearing dredging pumps and pumps with protective finish for tunnelling applications.



COMMON APPLICATIONS

AGGREGATES

Sand and gravel extraction, water processing, wet treatment, mineral extraction and processing

ENERGY INDUSTRY

Bottom ash, condensates, coal and coke processing

TUNNELING, CONSTRUCTION AND SPECIAL CIVIL ENGINEERING

Trench wall cutting, slate, marble, granite, wet sand treatment, sand & gravel, micro tunneling, vertical trenching (dry and wet wells), dredging (harbors, rivers)

MINING

Heavy mining slurry, mill scale and separation, ferric oxide production, ore slurry, coal, ore, phosphates, potash, bauxite, ceramics, Fe, Zn, Cu, Ti, Salt, Al, etc.

SUGAR PRODUCTION AND AGRICULTURAL WASTE

Beet pulp, washing installations, livestock waste

STEEL INDUSTRY

Furnaces, hot rolling mills

PERFORMANCE CHARACTERISTICS OF KB

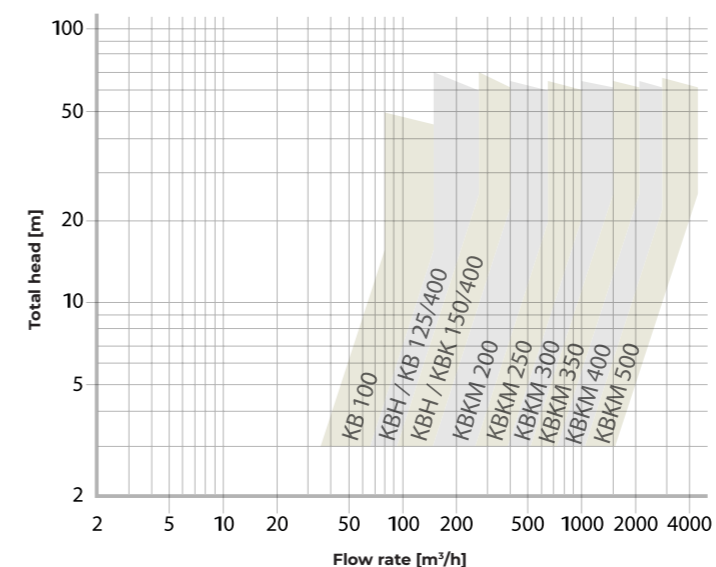

Performance characteristics of KB / KBK / KBH / KBKM / KBKT

Flow rate, up to	50-5000 [m³/h]
Maximum head	85 [m.l.c]
Pump speed, depending on the size, up to	2000 [min ⁻¹]
Pump sizes	DN 100 to DN 500
Maximum operating pressure	10 [bar]
Temperature of the slurry, up to	100 [°C]
Static head	8 [mW.C.]
Discharge nozzle arrangement	gradually rotatable
Highly corrosion resistant at pH levels	3 to 14, depending on materials

KBKT SERIES FOR SPECIAL CIVIL ENGINEERING



KBKT-VI mounted in a trench cutting machine

In today's construction industry the use of modern shaft sinking systems or diaphragm wall milling machines are a common practice for initial shaft development, target shaft projects and diaphragm walls. Vertical boring is always conducted in a soil filled shaft or trench. During the trench cutting operations, the excavated soil containing mud, sand and various solids, is being continuously pumped by highly wear-resistant submersible pumps and then transferred to the adjacent separation system.

KB SERIES FOR TUNNEL CONSTRUCTION



KBH 150-450

Due to their compact design and limited space requirements, KB and KBH series are perfectly suited for use as feed pumps in micro tunneling. Highly wear-resistant materials, unique configuration of hydrodynamic sealing system composed of relief impeller and gland packing, ensure smooth operation in AVN mode "automatic tunnelling with wet slurry circuit".

C&H

CHALLENGER & HERACLES

SUBMERSIBLE PUMPS FOR PROCESSING SOLIDS

Possible immersion depth of these verticale submersible pumps is up to 30 meters.

30 m

Challenger & Heracles designs are robust, exceptionally reliable pumps with flanged submersible motor for wet installations. Typical applications include mining, extraction of fine sand, sludge dumps, drainage of dams and cleaning lakes, ponds, and rivers. Only reliable and long-proven designs of HPK, NPW and KB series are used for the construction of these

wear-resistant pumps. Today's new technologies in pump production allow us to build an even better geometry of the slurry flow path. The result is a significantly improved efficiency and a longer service life of the casing and wet parts compared to other pump manufacturers. The three main differences between Heracles and Challenger are the drive method, the passage dimension and the shaft seal type. These pumps can be adapted to the properties of the process media, which makes them suitable for use with neutral, alkaline and lightly acidic media.



Find more information about this series on our website.

CHALLENGER

SUBMERSIBLE PUMPS FOR MEDIUM WEAR APPLICATIONS

Challenger has various drive installation methods. The pump is easily transportable and user friendly. There are two designs available: pump with metallic finish (CRM) and pump with polyurethane APFlex lining (CRP). Both pumps are available with and without an agitator.

Performance characteristics of Challenger

Flow rate up to	950 [m³/h]
Maximum head	56 [m.l.c]
Pump speed, depending on the size, up to	1470 [min⁻¹]
Cable length from	8 m
Submersion depth up to	30 m
Temperature range	+12°C to +40°C
Optional temperature range (with anti-condensate heater)	+4°C to +40°C
Pump sizes	DN 32 to DN 250



METALLIC PUMP CRM TYPE

CRP PUMP WITH POLYURATHANE LINING

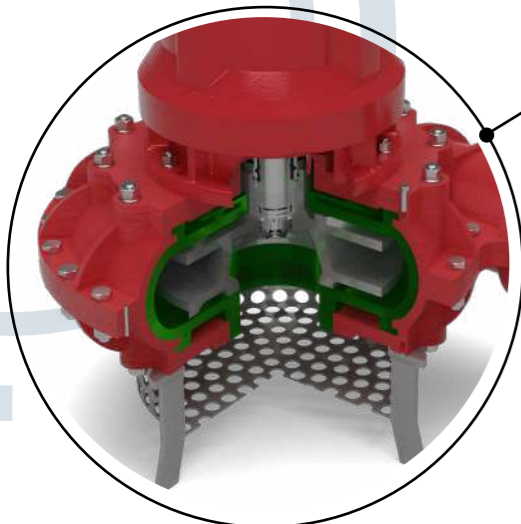

Motors, pump designs, as well as additional components are compatible with one another and can be easily combined, therefore create an individual design depending on the application.

HERACLES

SUBMERSIBLE PUMPS FOR HEAVY-DUTY OPERATIONS

Heracles has a special shaft seal, which allows heavy-duty operations to run smoothly and continuously. The pump can be configured with both electric and hydraulic motor. The units with hydraulic drive are especially designed with a direct connection to mobile construction machinery, such as crawler or wheel excavators. The pumps are directly connected to the hydraulic circuit and can therefore be controlled from the driver's cab.

Performance characteristics of Heracles

Flow rate up to	600 [m³/h]
Maximum head	52 [m.Llc]
Pump speed, depending on the size, up to	1475 [min⁻¹]
Cable length from	8 m
Submersion depth up to	30 m
Temperature range	+12°C to +40°C
Optional temperature range (with anti-condensate heater)	+4°C to +40°C
Pump sizes	DN 100 to DN 250



HERACLES PUMP WITH ELECTRIC MOTOR

HERACLES PUMP WITH HYDRAULIC MOTOR

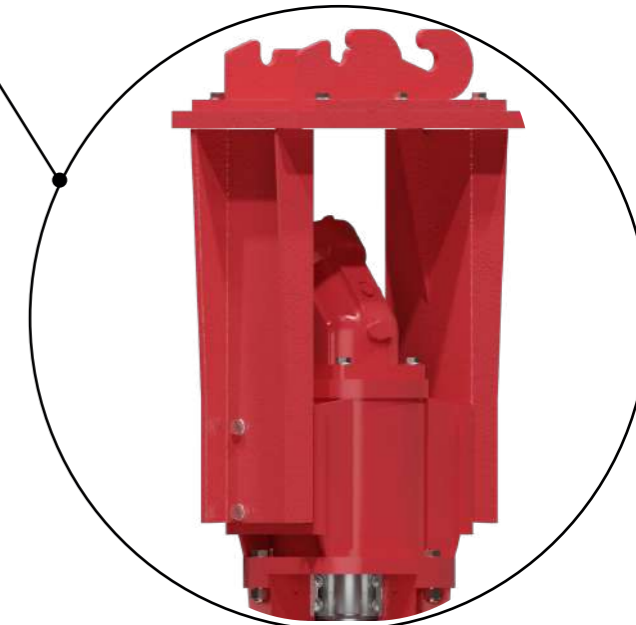

VERTICAL

VERTICAL PUMPS

VERTICAL PUMPS FOR WET AND DRY INSTALLATIONS

Possible immersion depth is up to 5 meters.

5 m

This construction series can be used for both wet and dry installations. Thanks to the modular structure of our pumping systems, vertical pumps may have the same configuration as HPK, NPK, and NPW series. The available installation depth of up to 1800 mm is suitable for V300 / V320 / V330 series.

These robust pumps are designed to tolerate high concentrations of solids and are fitted with cantilever shaft without a shaft seal. Furthermore, the V330 type is suitable for foaming and gas liquids and discontinuous operation. Additionally, this type may be equipped with shaft seals. The immersion depth for V1 / V2 series is up to 5000 mm. The hydraulic system is identical to the one in horizontal pumps of HPK, NPK, and NPW series and therefore has the same power range.

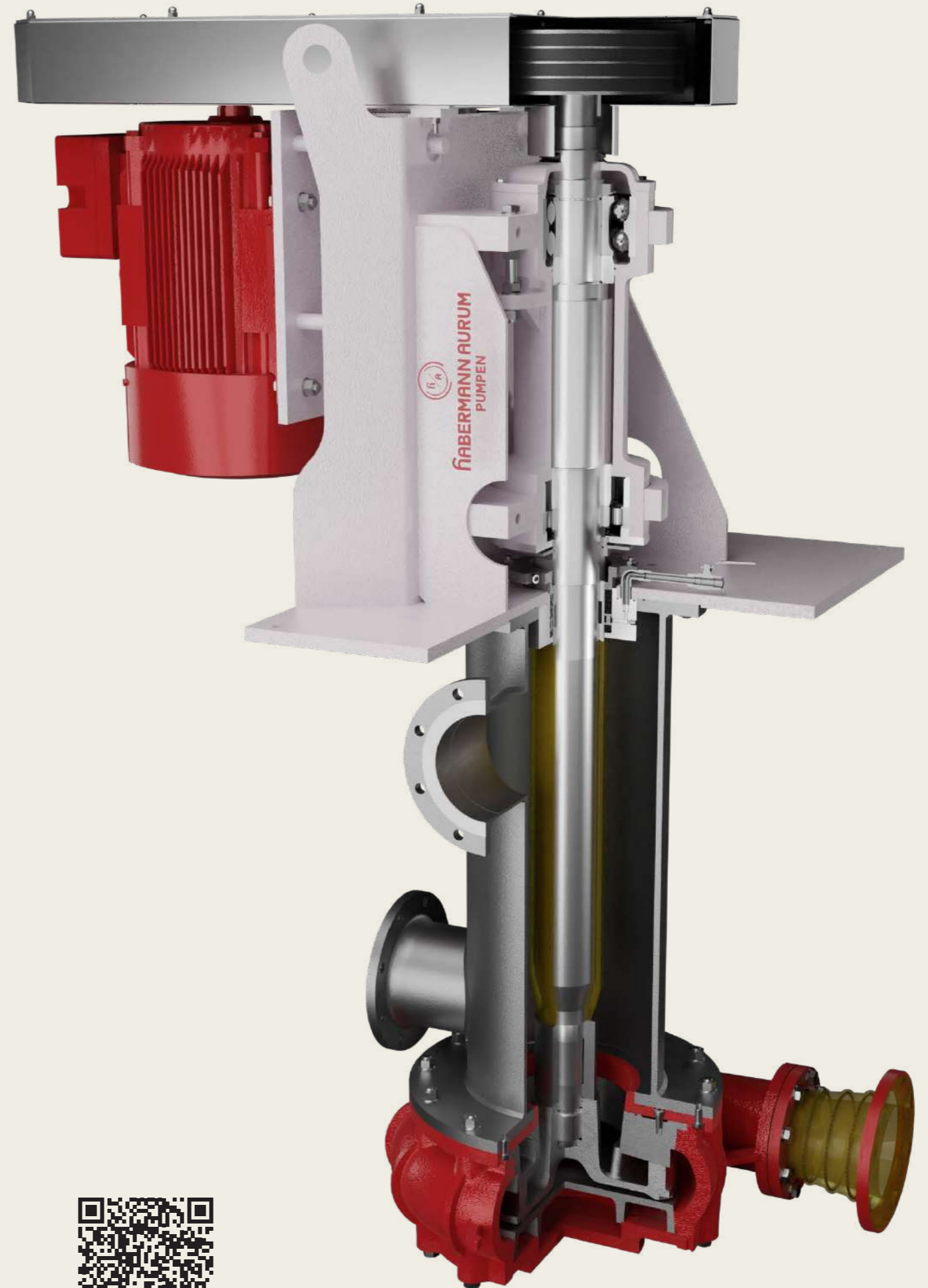

Find more information about this series on our website.

V300 / V320 SERIES

VERTICAL SEMI-SUBMERSIBLE PUMPS FOR WET INSTALLATIONS

The types V300 / 320 / 340 are vertical semi-submersible seal less pumps suitable for immersion depth up to 1800 mm. Due to the modular construction of Habermann's pumps, the hydraulic components of the V series are exactly the same as in HPK, NPK, and NPW pumps.

Performance characteristics of V300 / V320

Flow rate, up to	1400 [m³/h]
Maximum head	50 [m.l.c]
Pump speed, depending on the size, up to	2000 [min⁻¹]
Pump sizes	DN 32 to DN 300
Maximum operating pressure	10 [bar]
Temperature of the slurry, up to	90 [°C]
Highly corrosion resistant at pH levels	0 to 14
Standard installation depth	H = 500 / 900 / 1100 / 1350 / 1500 / 1650 / 1800 [mm]

Standard drive V-Belt drive, direct motor coupling is possible, depending on the operating point



WET WELL INSTALLATION

Static head	Maximum fluid level	Minimum ground clearance
$h_z = DN + 150 \text{ mm}$	$a_{\min} = 1 \times DN$	$h_{\min} = 1.5 \times DN$

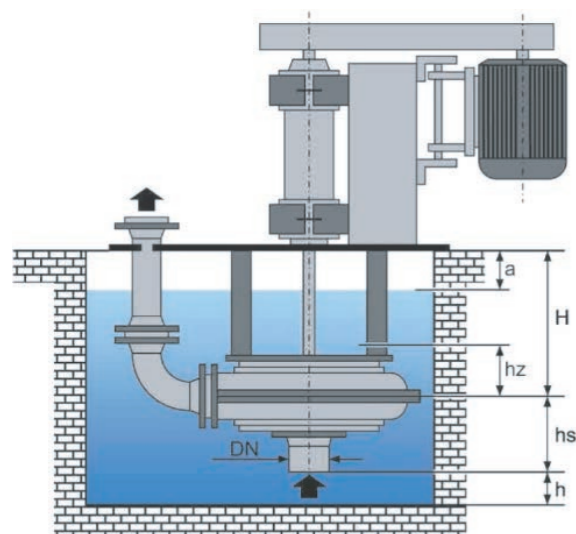

Wet installation **V300**

(Maximum suction height $h_s = 2500 \text{ mm}$)

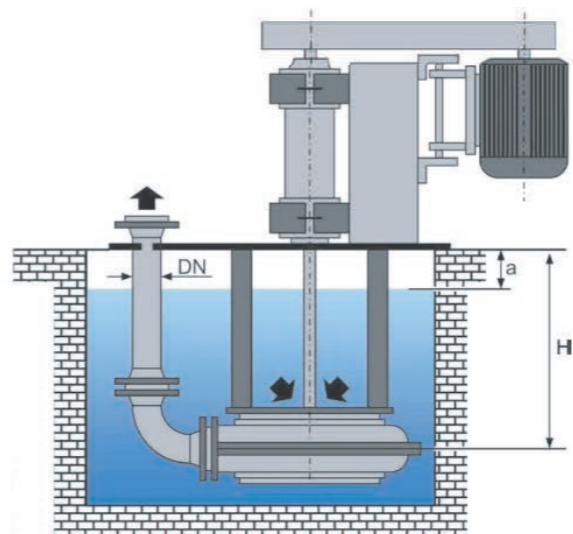

Wet Installation **V320**

V330 SERIES

VERTICAL PUMPS FOR DRY INSTALLATION

V330 series are vertical pumps with an open system designed for froth pumping applications. Due to the special construction of the pump with its own ventilation pipe, V330 type is mainly used in flotation processes, in particular for transportation of aerated slurries. The pumping media flows into the pump through its suction inlet, then the rotating impeller discharges the liquid towards the pressure pipe. Meanwhile the gas or air bubbles in the liquid are released to the atmosphere through the ventilation pipe. This construction is called open system, which is well-suited for discontinuous operation and changing inlet conditions.

Performance characteristics of V310 / V330

Flow rate, up to	1600 [m³/h]
Maximum head	50 [m.l.c]
Pump speed, depending on the size, up to	2000 [min⁻¹]
Pump sizes	DN 32 to DN 300
Maximum operating pressure	10 [bar] (2-stage up to 16 bar)
Temperature of the slurry, up to	90 [°C]
Highly corrosion resistant at pH levels	0 to 14
Standard installation depth	H = 500 / 900 / 1100 / 1350 / 1500 / 1650 / 1800 [mm]

Standard drive V-Belt drive, direct motor coupling is possible, depending on the operating point



DRY INSTALLATION

Minimum suction head during the pump start-up	Maximum water level	Minimum ground clearance
$h_z = DN + 150 \text{ mm}$	$a_{\min} = 1 \times DN$	$h_{\min} = 1.5 \times DN$

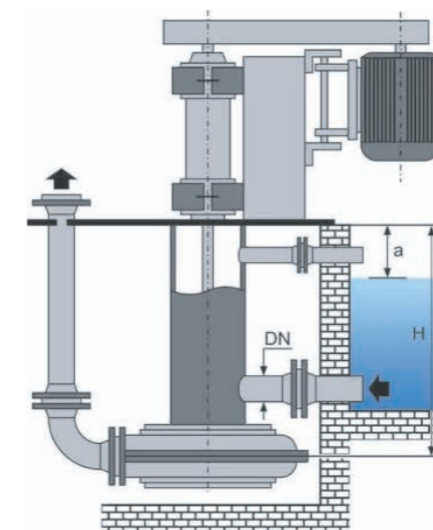

Dry Installation **V330**

V1 / V2 SERIES

VERTICAL CENTRIFUGAL PUMP

These construction types are suitable for both wet and dry installations. The hydraulic components correspond to those in HPK, NPK, and NPW series. In case of dry installed pump, its hydraulic components are protected with mechanical shaft seal.

V1 Type

The installation depth for this type is up to 2500 mm or greater with the use of additional shaft seals. The design is suitable for both wet and dry installations.

V2 Type

This type features an extended linear shaft: the drive shaft is designed in two parts, connected with an intermediate coupling. Due to this design, the permissible installation depth for this type is up to 5000 mm.

Lubrication System

The integrated lubrication of the bearings and shaft seals ensure efficient operation of the pump under heavy-duty applications.

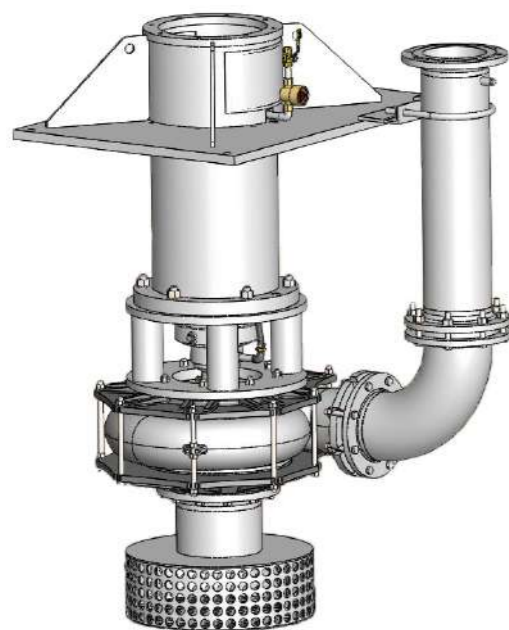

NPW 200 V1

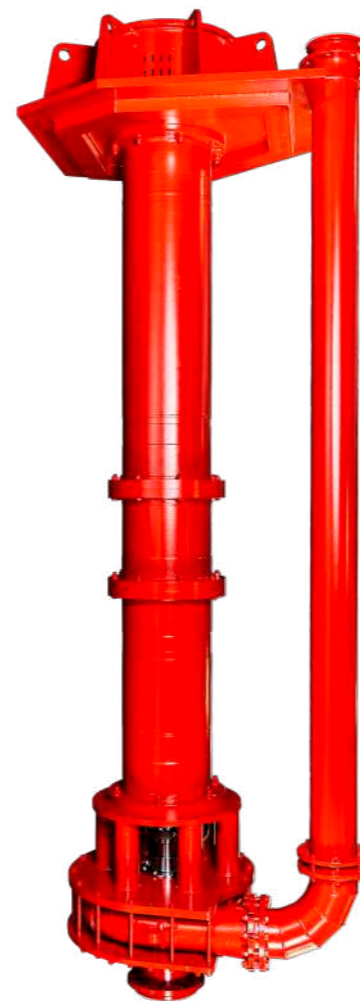

V2

Performance characteristics of V1 / V2

Flow rate, up to	2500 [m ³ /h]
Maximum head	60 [m.l.c]
Pump speed, depending on the size, up to	1480 [min ⁻¹]
Pump sizes	DN 32 to DN 400
Maximum operating pressure	10 [bar]
Temperature of the slurry, up to	70 [°C]
Highly corrosion resistant at pH levels	3 to 14
Discharge nozzle arrangement	gradually rotatable

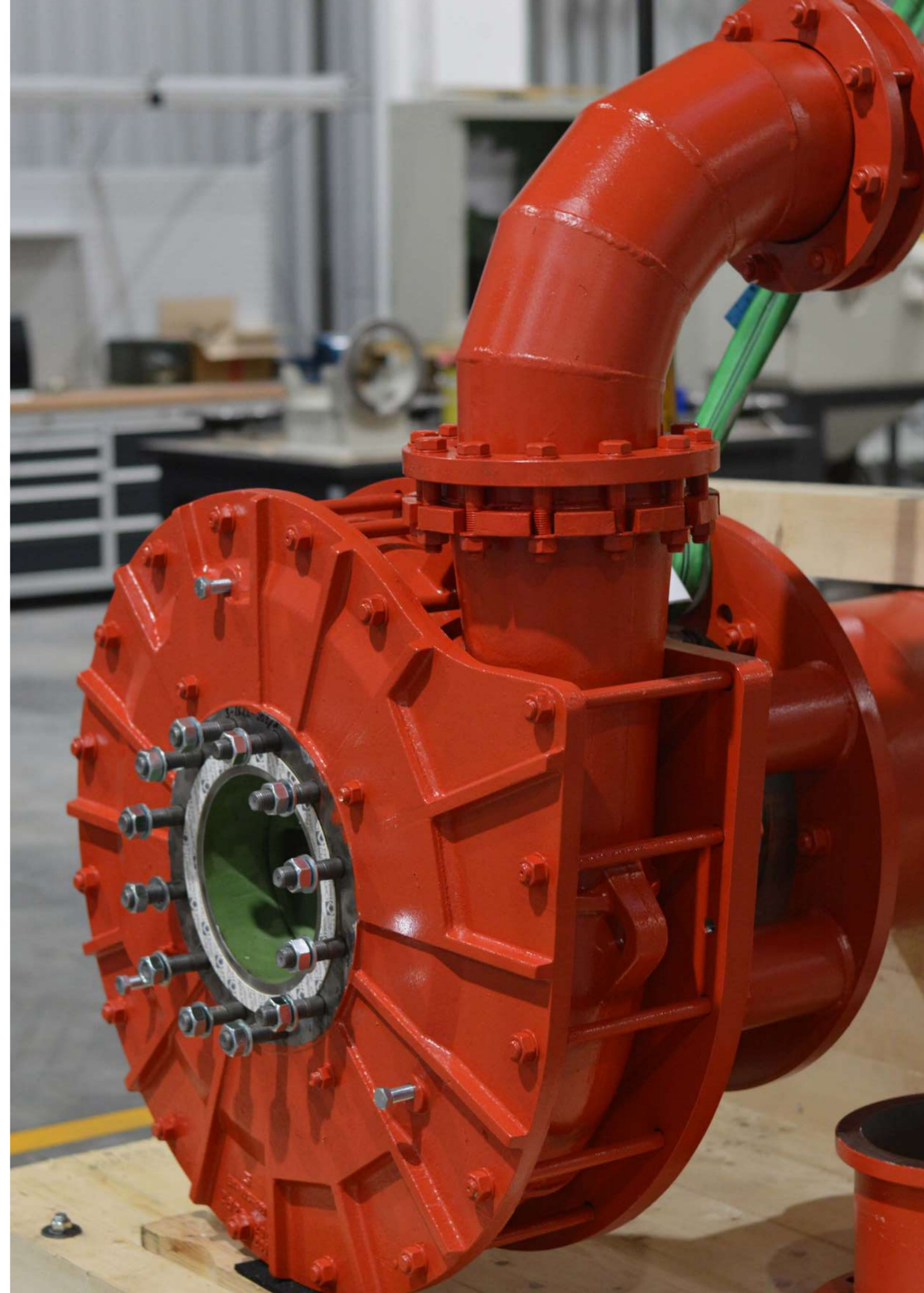

SPECIAL SUMP DESIGN N

CENTRIFUGAL SUMP PUMPS

This special design with its own sump container is used for processing media with air bubbles, foaming liquids and discontinuous pumping conditions. The design is intended to regulate the pumping volume, which means that the flowing fluid, distributed from the shaft side, adjusts to the maximum construction capacity (discontinuous operation). These pumps can be fitted with the hydraulics of the HPK, NPK and NPW series.

ADVANTAGES:

- Efficient pumping of foaming and gas liquids thanks to the upturned angle of the impeller
- Due to the self-supporting structure of cantilever shaft, shaft seals are not necessary
- Elastic lining and metallic finish versions are both available
- Dry installation of the bearing bracket and drive components
- Available sump container / basin volume of up to 2,5 m³



The materials and the sump container geometry are selected according to individual requirements of the operating conditions and the type of fluid.

Performance characteristics of N

Flow rate, up to	1400 [m ³ /h]
Maximum head	50 [m.l.c]
Pump speed, depending on the size, up to	2900 [min ⁻¹]
Pump sizes	DN 32 to DN 300
Maximum operating pressure	10 [bar]
Temperature of the slurry, up to	90 [°C]

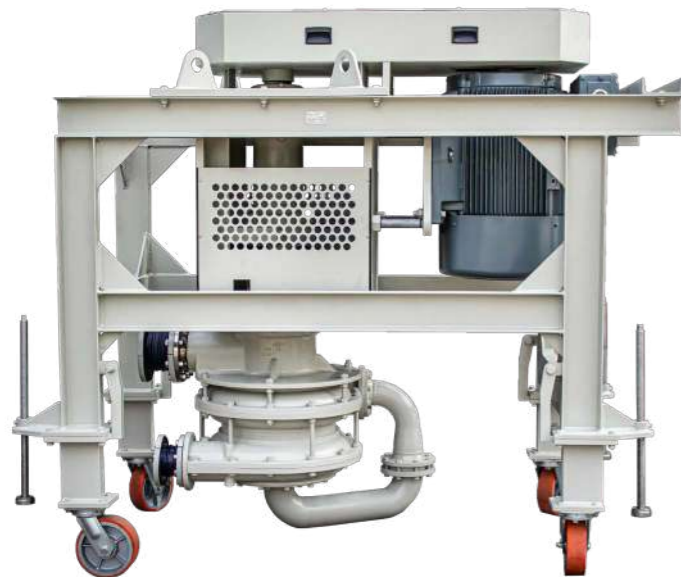

HPK V330 N two-stage pump

SHAFT SEALS

MATERIALS



SHAFT SEALING WITH PACKING SEAL

Shaft protective seals are extremely important and must be assembled for prevention the passage of fluids along a rotating shaft. To prevent any inappropriate operation, shafts must have a reliable and secure sealing system that will shield them away from harmful solid particles contained in the working media. Depending on the operating conditions, the shaft is sealed using either packing seal, mechanical seal, or hydrodynamic seal with an expeller.

STANDARD DESIGN OF THE GLAND PACKING SEAL

In addition to the excessive pressure on the gland packing, insufficient lubrication of the seal components can cause the seal to start over-leaking and wear over time. However solid particles slipping into the seal arrangement is ultimately what creates the efficiency loss and the need for the seal to be repacked.

To relieve the pressure on the gland packing, the impeller is equipped with back relief blades. In order to keep abrasive particles away from the vulnerable seal components, the seal is flushed with the sealing fluid.

The locking ring (1) of the seal is injected with the sealing fluid on the discharge side, which ensures the necessary lubrication of the packing rings (2).

Additionally, it is recommended to install a throttle valve and manometer to set the required pressure and to adjust the amount of the sealing fluid in packing rings. To control the flow of the

sealing fluid, a flow control display should also be installed. Sealing fluid enters the locking ring chamber (3) and from there moves to the packing rings (2) via the shaft clearance (4). It flows through the radial holes in the locking ring and via fixed pipe (5) into the locking ring (6), on the suction side. Then the sealing water flows into the pump

casing via the shaft clearance (7). The sealing pressure must be at least 0.3 bar greater than the pressure on the impeller hub. To make it easier to replace the packing rings on the suction side, the gland packing has an axially split housing.

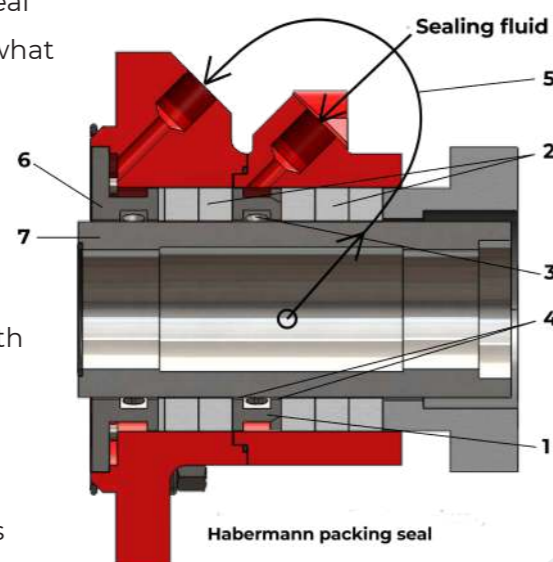

Alternatives to packing seal:

- Single-acting mechanical seal
- Double-acting mechanical seal comprising of HGD-1 mechanical seal on the suction side, mechanical seal on the discharge side and the quench chamber
- Hydrodynamic seal with an expeller and gland packing
- Stationary seal for special pumps

SHAFT SEALING WITH MECHANICAL SEAL



DOUBLE-ACTING MECHANICAL SEAL

Mechanical seals are available in various designs to handle diverse operating conditions. Due to our precisely machined assembly, the leakage from mechanical seal is extremely low. Our innovative design can withstand high pressures from 16 up to 25 bar. A complex pressurized sealing system is not required. The hydraulic and mechanical forces generated during operation create a tight and leak-free arrangement and prevent solid particles from entering the seal. The space between two seals is lubricated and cooled by means of cooling water.

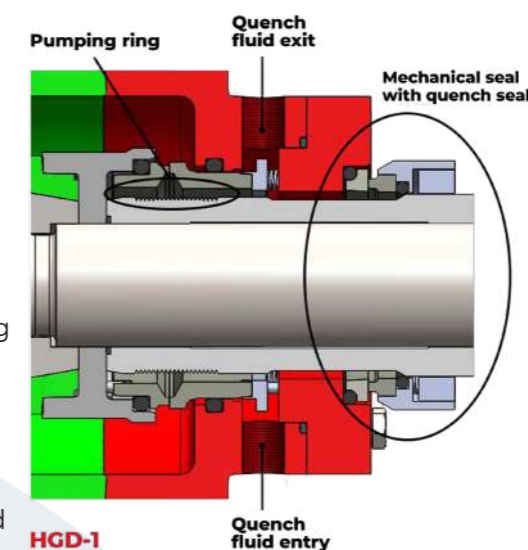

When the seal is flushed, the water entry pressure should not exceed 0.5 bar. With

mechanical seals ranging from $\varnothing 43$ to $\varnothing 100$ in size, cooling water consumption is about 5-20 l/h.

As an alternative, thermosyphon system with unpressurized quench fluid may be used to flush the seals. Since the fluid absorbs

the friction from the seals, it is cooled and recycled in a closed

loop. In addition, the quench fluid must be extremely clean (drinking water), as the seal is

quite sensitive to the abrasion by solid particles. The transfer port on the protective shaft sleeve supports fluid's recirculation in the seal.

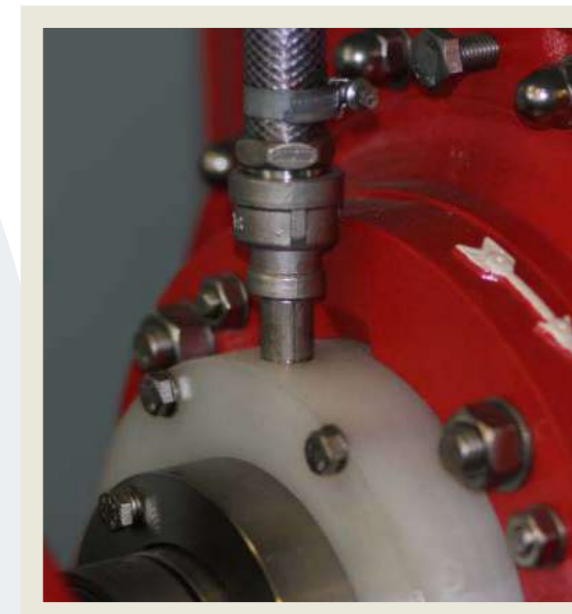

HGD-1
CARTRIDGE VERSION

The cartridge seal version is based on a proven HGD-1 design. It consists of an entirely pre-assembled and factory tested seal unit, which allows to avoid assembly errors. After installing it into the pump, the only thing left to do is to remove the assembly locks and the seal will be ready for operation. It is not necessary to realign the primary seal after impeller adjustment. The self-adjusting design ensures the seal alignment to be compensated automatically. The HGD-1 cartridge version is available in both double and single mechanical seal types.

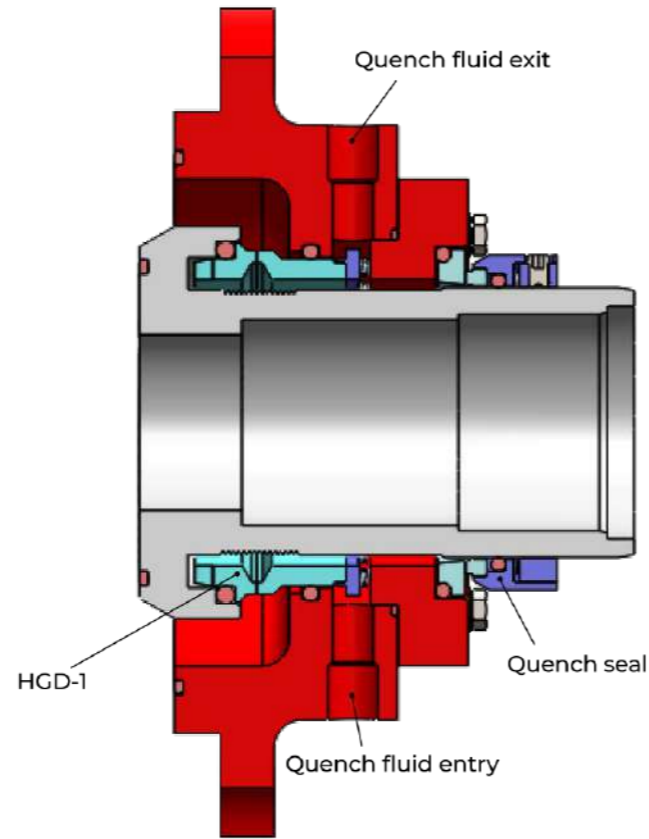

HGD-2
MECHANICAL VERSION

The HGD-2 is a further modified HGD-1 version and is the mechanical seal used for polyurethane lined impellers of the HPK series. Similarly to HGD-1, HGD-2/QD shaft seal is suitable for operating pressures up to 25 bar.

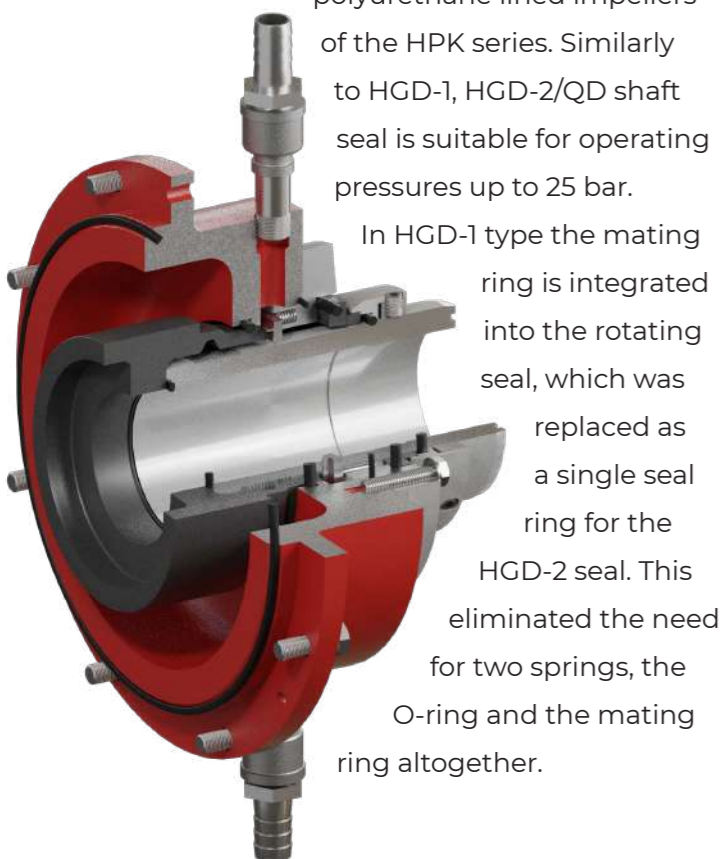

Thereby, the cooling water located in the quench chamber is not exposed to the pumped media, and the compact seal design enables relatively simple and fast installation in case of repair.

The other advantages, such as the elimination of a complex pressurized sealing system, direct cooling of the seal rings through the quench chamber, and restricted entry of solid particles due to generated rotational forces, are identical to those of HGD-1 type. The required cooling water consumption of approx. 5-20 l/h is also similar to the HGD-1. Alternatively, as with HGD-1, an unpressurized thermosiphon system can also be used. The transfer port on the protective shaft sleeve supports fluid's circulation for cooling and lubrication of the seal.

HGD-1 / HGD-2
COMPARISON

HGD-2 type is just as reliable as HGD-1, but has a more compact design. In HGD-1 type the mating ring (Item 495) is integrated into the rotating seal (Item 459), which was replaced by a single seal ring (Item 459) for HGD-2. As a result, springs (item 495.1), the O-ring (item 477) and the mating ring (item 495) are no longer required for the overall assembly.

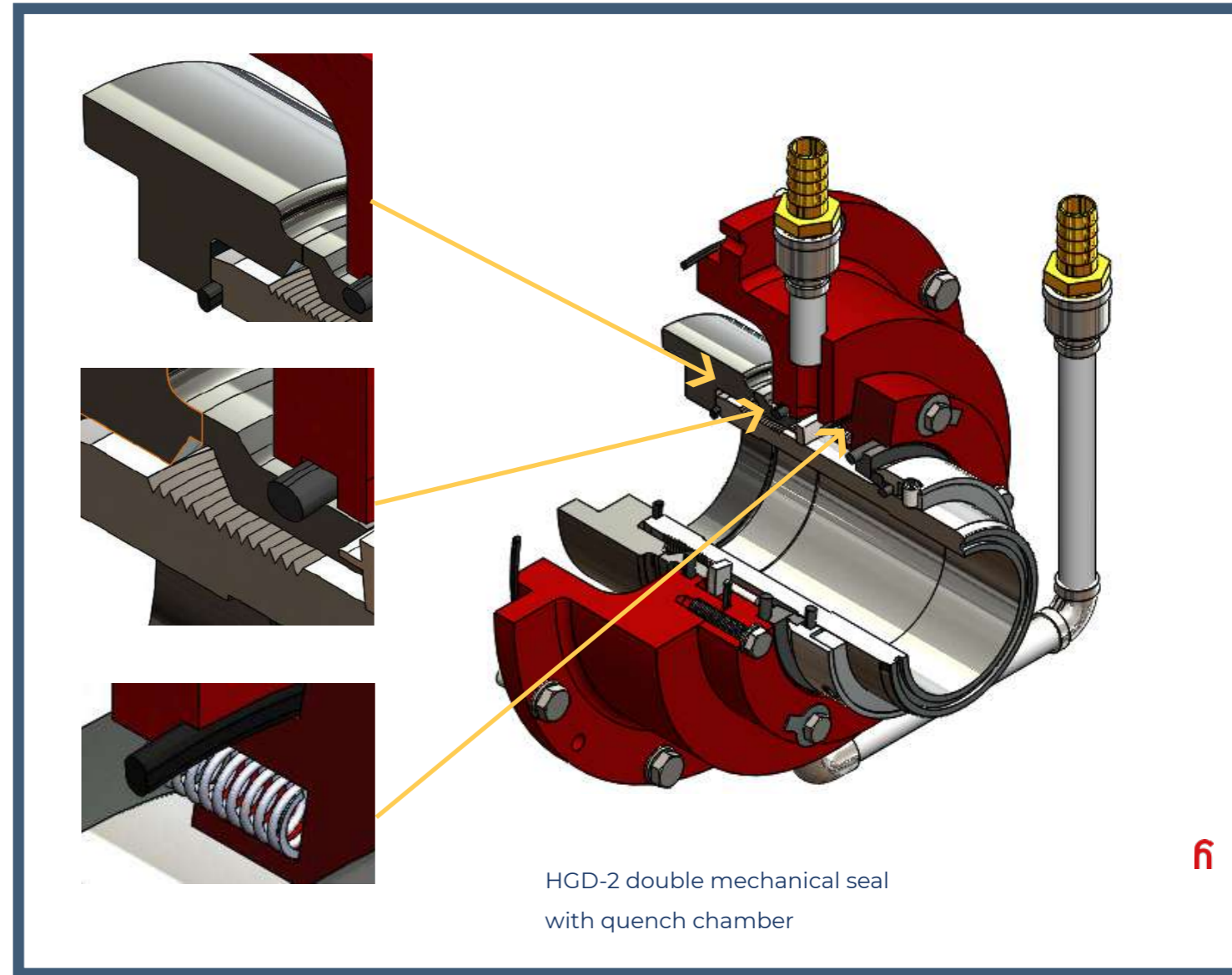
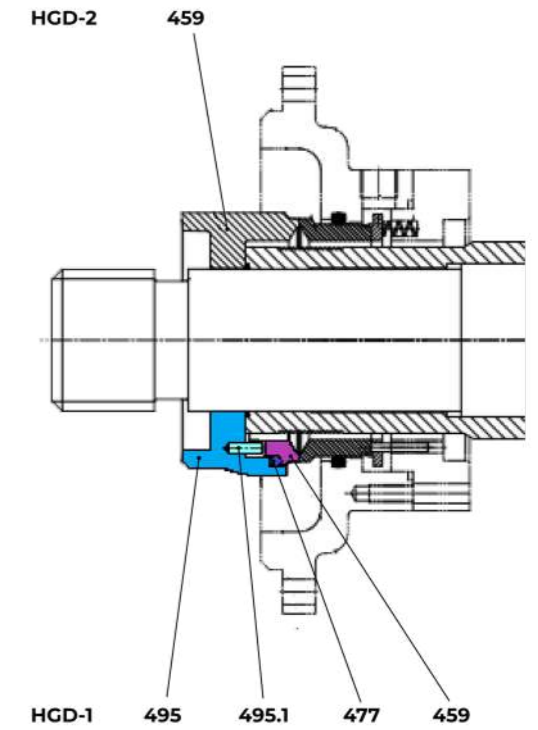

HGD-2 double mechanical seal with quench chamber

SEALING WITH HYDRODYNAMIC SEAL

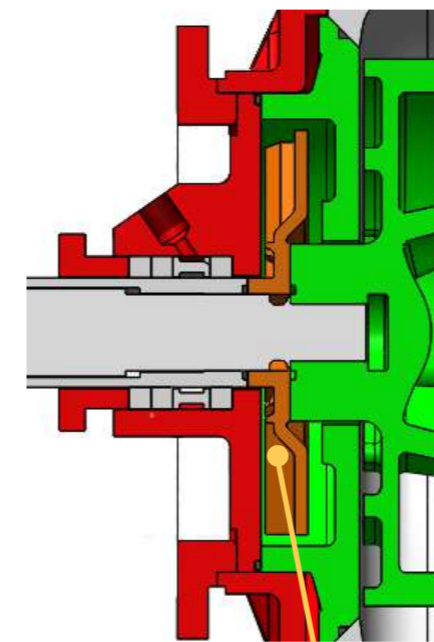

EXPELLER

Shaft sealing by means of expeller, also known as relief impeller, is available for most of our pump series. This sealing type is particularly suitable for fine-grained pulp. It can be used as an alternative to mechanical seals for extreme applications or if the supply of clean sealing water is not possible due to the installation conditions. The application limit is close to the boiling point of the pumped media. The gland packing serves as a stationary seal and the expeller - as a dynamic component. The most commonly used materials for the relief impeller are metal and polyurethane.

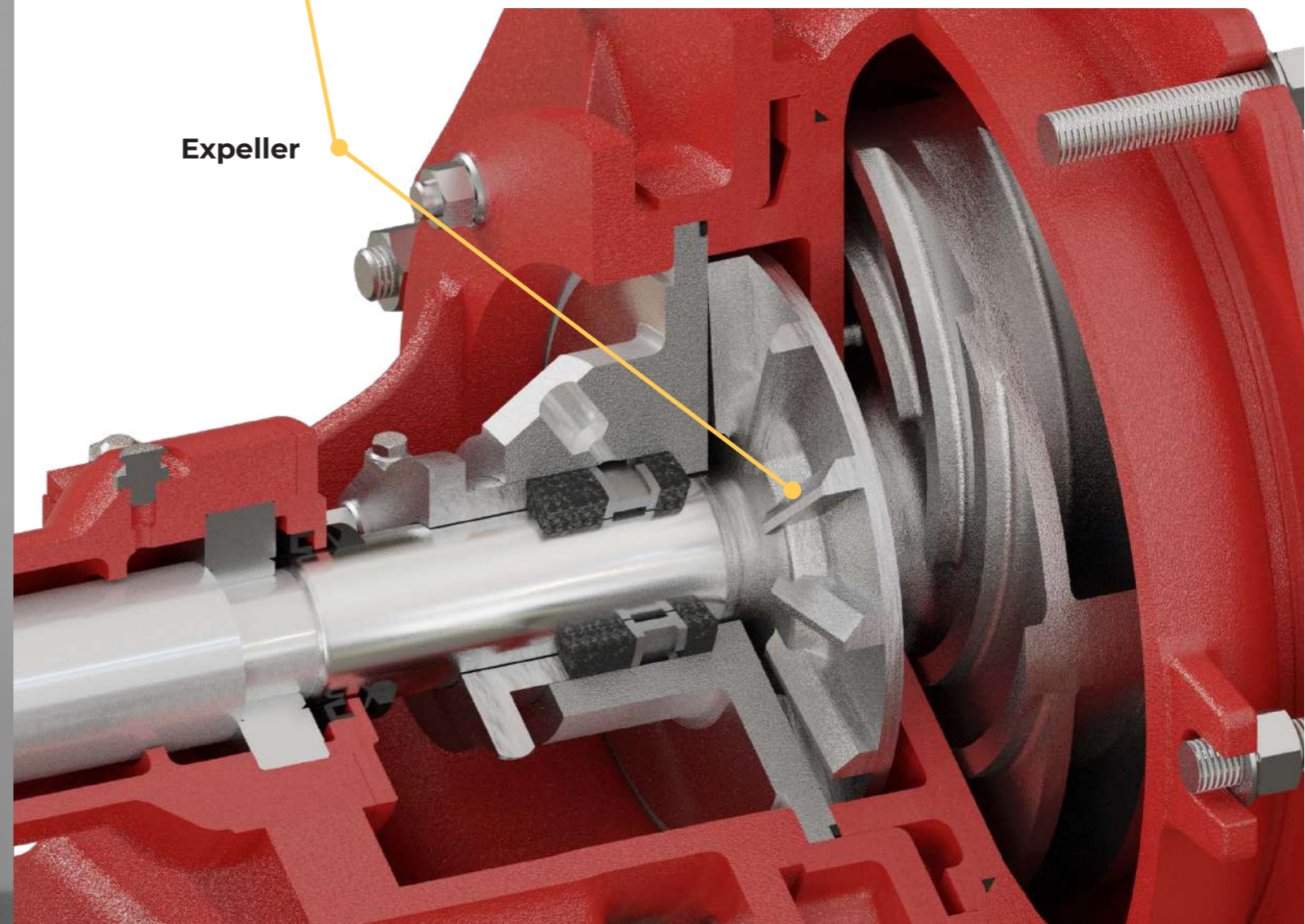
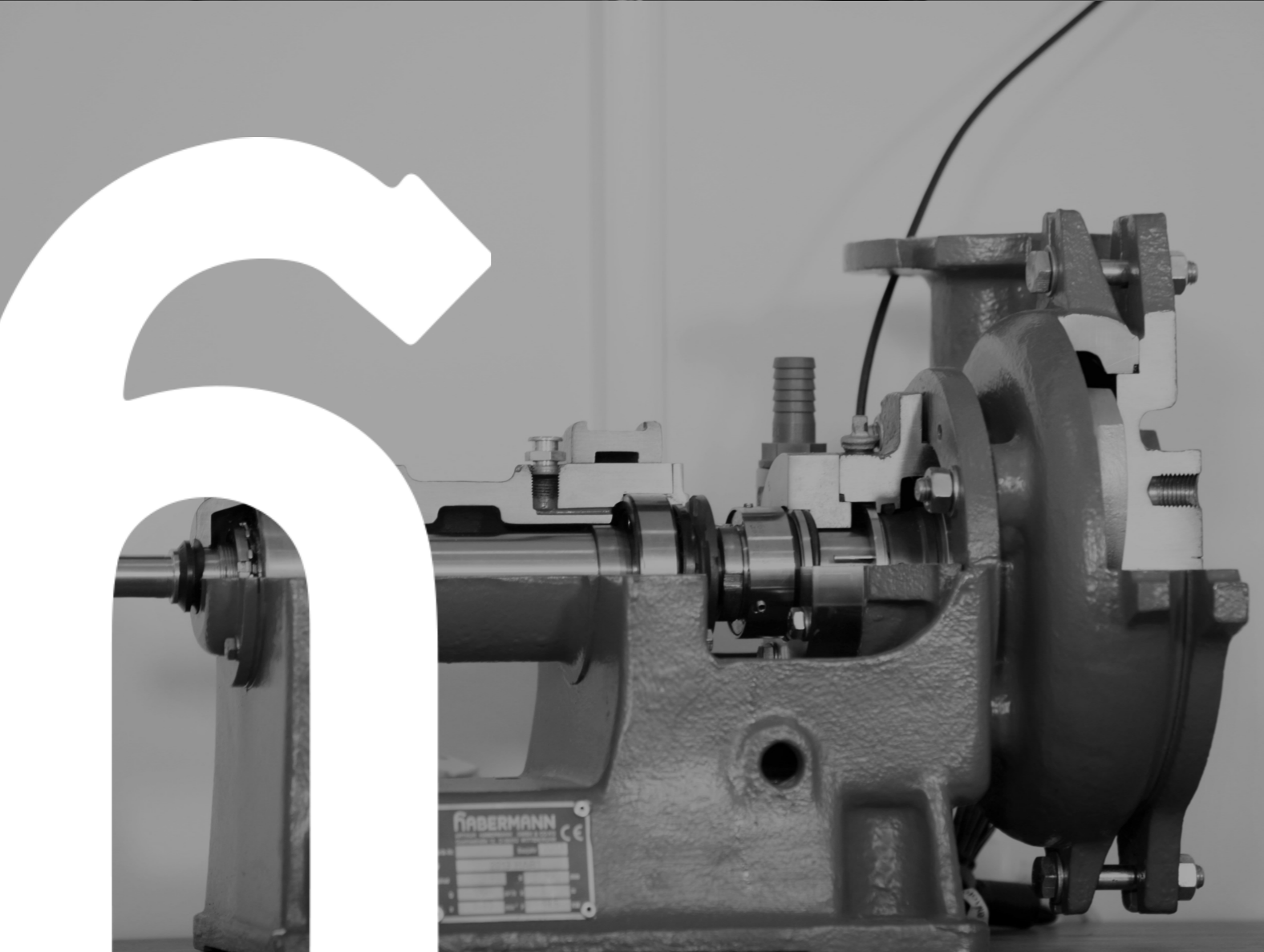

CASTING MATERIALS

Highly wear-resistant casting materials from Habermann Aurum Pumpen were modified and perfected throughout the years based on our own experience and research. We have developed wear and corrosion resistant alloys specifically for pumps processing aggressive media and used for medium to heavy duty applications. Due to their unique combination and high hardness level, these materials significantly improve mechanical properties of the pump components. In addition to tempered steel and duplex steel, we offer cast materials of our own alloy development that are tailored to respective applications: HBN 440, HBN 450, HBN 480 with a Brinell hardness of up to 650 HB.

WEAR AND CORROSION RESISTANCE

OF VARIOUS HABERMANN AURUM MATERIALS

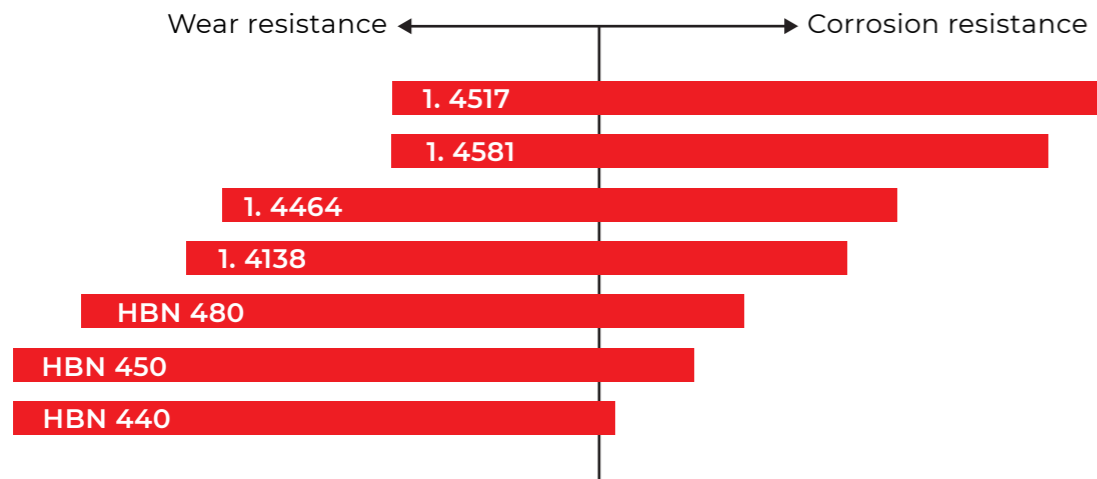

MATERIALS AND THEIR HARDNESS ACCORDING TO BRINELL SCALE

Material No.	Hardness [HB]
1.4517	230 - 300
1.4581	130 - 200
1.4464	230 - 300
1.4138	260 - 330
HBN 480	620
HBN 450	650
HBN 440	600

DRIVES AND
INSTALLATION METHODS

PUMP CONFIGURATIONS

PUMP SERVICE AND
SPARE PARTS

DRIVES AND INSTALLATION

V-BELT DRIVE

Slurry pumps are directly coupled with the electric motor only in exceptional cases. This method may be accommodated in case of compatible motor speed, depending on the pump size.

Today, the most commonly used drives are V-belt drives with high motor powers of up to 315 kW. The taper lock bushes make it easier to install and remove the V-belt pulleys, eliminating the need for tensioner to hold it together. Further advantage of the V-belt drive is that the operating characteristics of the pump can be easily adapted to the workflow changes by replacing the V-belt pulleys. This flexible design with easy installation and alignment has a very long shelf life and high efficiency.

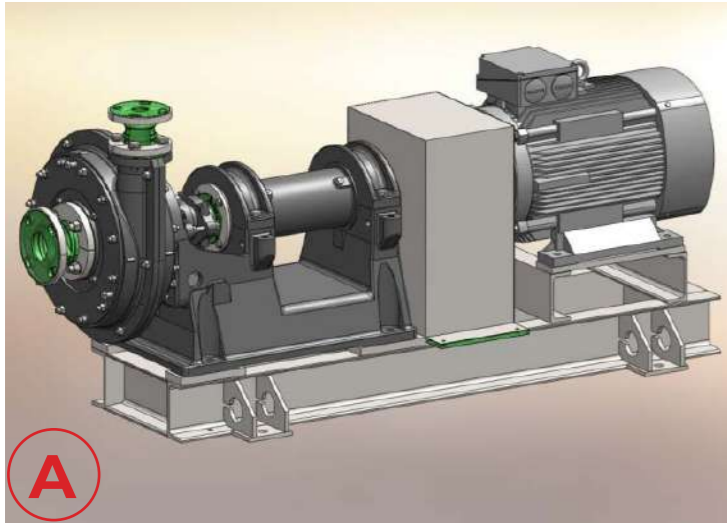

A

Direct coupling

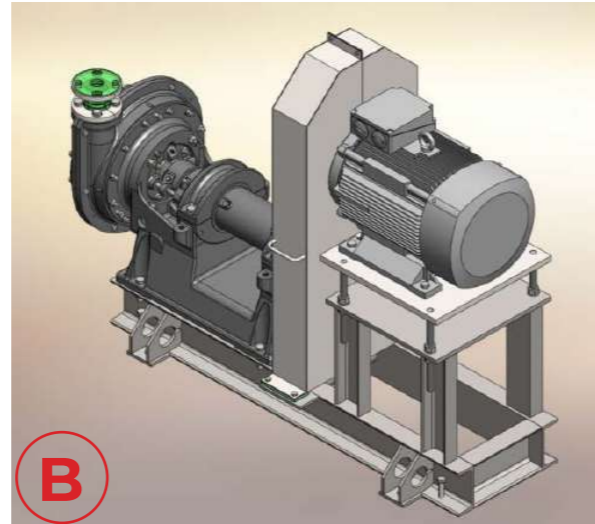

B

V-belt drive with e-motor mounted in longitudinal axis of the pump

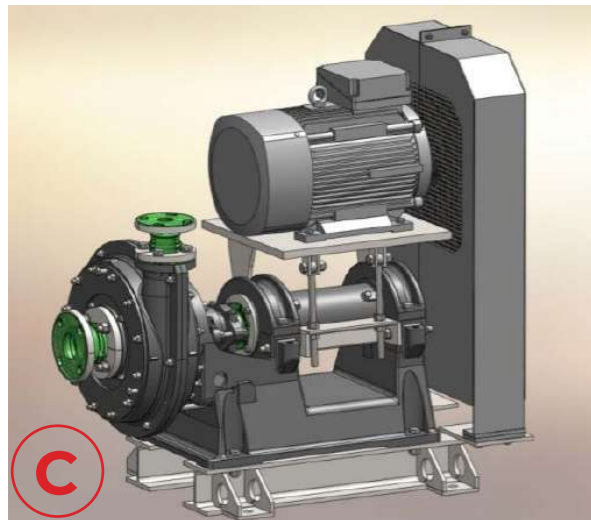

C

V-belt drive with e-motor mounted above the pump bearing

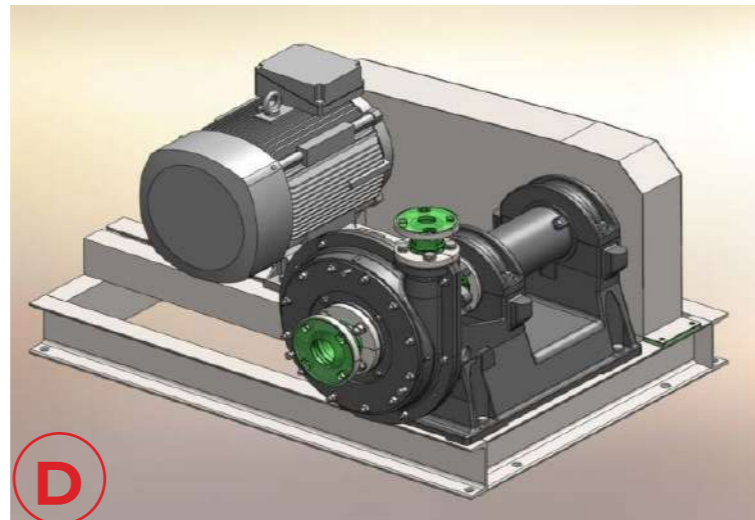

D

V-belt drive with e-motor next to the pump on the suction side, to the left or right optionally.
(On request, with separate base frames for pump and motor)

PUMP CONFIGURATIONS

All pump series are available in horizontal and vertical configurations for wet and dry installations with installation length of up to 5 m. It is also possible to use them as submersible pumps with hydrodynamic sealing system or as sump pumps without shaft sealing.

HORIZONTAL PUMP

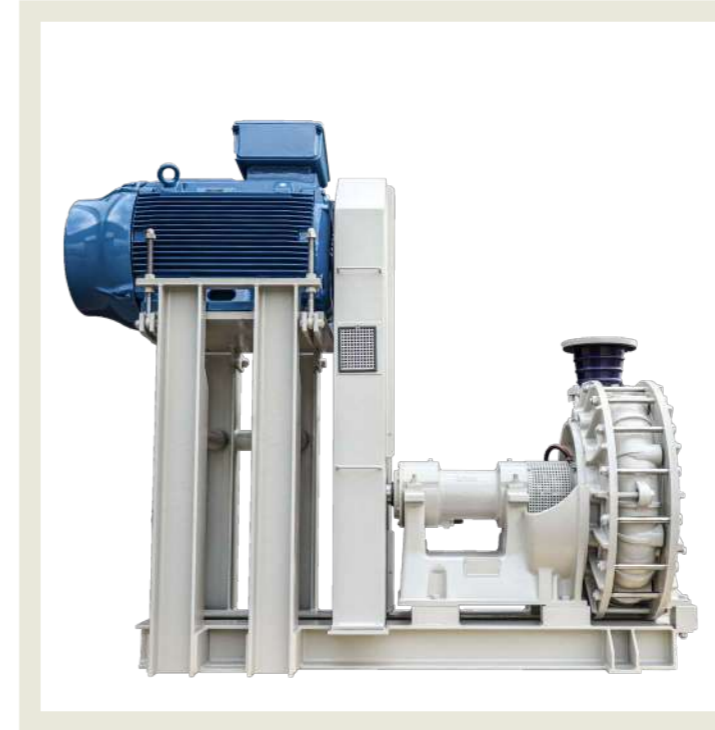

VERTICAL PUMP

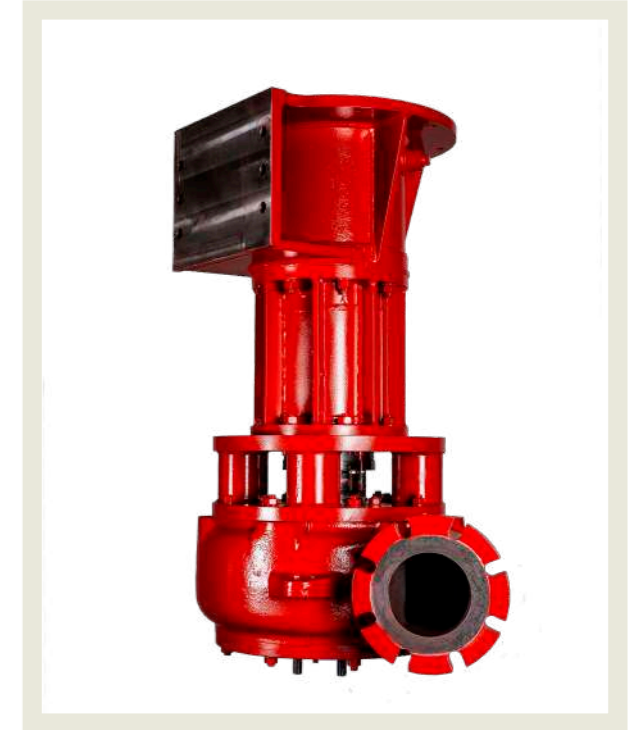

SUBMERSIBLE PUMP



SPECIAL DESIGN





The best pump does
what it is supposed to do:
pump.



PUMP SERVICE

Our professional team of experts is here to offer you complete optimization and repair services to ensure the safety and efficiency of your pumping system. Our goal is to not only properly repair your pump, but to clarify why a possible failure could occur and ensure that all pump components are in fully operational condition.

SPARE PARTS

With original spare parts from Habermann Aurum Pumpen, you get the highest quality and functionality when replacing individual components. Powered by our multi-decade experience and a vast network of partners, we can support you with suitable products and solutions globally.

MODERNIZATION

Our modernization services allow you to modify and improve Habermann Aurum pumps and systems that have been in operation for a number of years. Whether you wish to maximize your production capacity or optimize specific processes within an application, we will assist you every step of the way. Thereby you can ensure an optimal performance across your network and extend your pump's shelf life without having to invest in new systems. We will work with you to find the best possible solutions that are tailored to your needs.

MAINTANANCE AND REPAIR SERVICES

- ✓ System analysis
- ✓ Pump optimization
- ✓ Productivity assessment
- ✓ Pump commissioning and integration
- ✓ Maintenance and repair services

WE HAVE THE SOLUTION FOR YOU
aftersales@aurumpumpen.de



**HABERMANN AURUM
PUMPEN**

WWW.HABERMANN-AURUM-PUMPEN.DE

**+49 (0) 234 893 570 0
INFO@AURUMPUMPEN.DE**

**HABERMANN AURUM PUMPEN GMBH
HARPENER HEIDE 14 | 44805 BOCHUM | DEUTSCHLAND**